



# **Sustainable Heat Use of Biogas Plants**

*A Handbook*

**BIOGASHEAT**



- Author: Dominik Rutz
- Co-Authors: Rita Mergner, Rainer Janssen
- Reviewers: Ilze Dzene, Claudio Rochas, Stefan Amann, Christof Amann, Jadranka Maras Abramovic, Christopher Gallasch, Laura Bailón Allegue, Jørgen Hinge, Frederico De Filippi
- Editor: Dominik Rutz
- ISBN: 978-3-936338-29-4
- Translations: The original language of the handbook is English. This handbook is also available in the following languages: Croatian, Czech, Danish, German, Italian, Latvian, Polish and Romanian
- Published: © 2012 by WIP Renewable Energies, Munich, Germany
- Contact: WIP Renewable Energies, Sylvesteinstr. 2, 81369 Munich, Germany  
Dominik.Rutz@wip-munich.de, Tel.: +49 89 720 12 739  
www.wip-munich.de
- Website: www.biogasheat.org
- Copyright: All rights reserved. No part of this book may be reproduced in any form or by any means, in order to be used for commercial purposes, without permission in writing from the publisher. The authors do not guarantee the correctness and/or the completeness of the information and the data included or described in this handbook.
- Disclaimer: The sole responsibility for the content of this handbook lies with the authors. It does not necessarily reflect the opinion of the European Union. Neither the EACI nor the European Commission are responsible for any use that may be made of the information contained therein.

## ***Acknowledgements***

This handbook was elaborated in the framework of the BiogasHeat project (IEE/11/025), supported by the European Commission through the Intelligent Energy for Europe (IEE) programme operated by the Executive Agency for Competitiveness and Innovation (EACI). The authors would like to thank the European Commission for the support of the BiogasHeat project as well as the reviewers and BiogasHeat partners for their contribution to the handbook.

For the provision of pictures and graphs, the authors thank the following companies: AgroEnergien (Burkhard Meiners), GE Energy (Roland Jenewein), LaTherm GmbH (Michael Schönberg), SCHNELL Motoren AG (Susanne Kerezsy), STELA Laxhuber GmbH (Nadine Sahlmann), Thermaflex Isolierprodukte GmbH (Jana Tanneberg-Kranz), TransHeat GmbH (Ronald Strasser), Tranter Solarice GmbH (Wolfgang Stürzebecher) and Verdesis Services UK LTD (Nick Sheldon).

## The BiogasHeat project

The BiogasHeat project addresses the problem of how to efficiently use the heat from biogas plants at the European, national and project level. Thereby a set of different policy, best practice, field test and project implementation measures are developed and used. The specific objectives of the BiogasHeat project are: (1) to support the economic and sustainable utilization of heat from existing and future biogas plants, which currently is wasted, (2) to increase the capability in several target countries (Austria, Croatia, Czech Republic, Denmark, Germany, Italy, Latvia, Poland, and Romania) through specific measures, including analysis of technical options, feasibility studies, entrepreneurial strategy development of business cases and field testing to address key barriers; and (3) to boost capacity through trainings, skills enhancement, and knowledge transfer.

BiogasHeat has started in April 2012 and lasts for 3 years. The project is supported by the Intelligent Energy for Europe Program of the European Union (Contract No IEE/11/025).

### Project Consortium and National Contact Points:



**Ekodoma**, Latvia (Project coordinator)  
Ilze Dzene [ilze@ekodoma.lv]



**WIP Renewable Energies**, Germany  
Dominik Rutz [Dominik.Rutz@wip-munich.de]  
Rita Mergner [Rita.Mergner@wip-munich.de]



**Energy Institute Hrvoje Požar**, Croatia  
Biljana Kulišić [bkulic@eihp.hr]  
Jadranka Maras Abramović [jmaras@eihp.hr]



**Energy Efficiency Center SEVEN**, Czech Republic  
Tomáš Voříšek [tomas.vorisek@svn.cz]



**Sogesca Srl**, Italy  
Federico De Filippi [f.defilippi@sogesca.it]  
Marco Devetta [m.devetta@sogesca.it]



**Polish Biogas Association**, Poland  
Michał Surowiec [michal.surowiec@pba.org.pl]



**e7 Energie Markt Analyse GmbH**, Austria  
Christof Amann [christof.amann@e-sieben.at]  
Stefan Amann [stefan.amann@e-sieben.at]



**Danish Technological Institute**, Denmark  
Laura Bailón Allegue [lbae@teknologisk.dk]  
Jørgen Hinge [jhi@teknologisk.dk]



**SC Mangus Sol Srl**, Romania  
Mihai Adamescu [office@mangus.ro]



**Euroheat&Power**, Belgium  
Christopher Gallasch [Christopher.Gallasch@euroheat.org]

# Content

<b>Acknowledgements</b> .....	<b>2</b>
<b>The BiogasHeat project</b> .....	<b>3</b>
<b>Preface</b> .....	<b>6</b>
<b>1 Introduction</b> .....	<b>7</b>
1.1 Biogas production .....	7
1.2 Biogas plant concepts .....	9
1.3 Concepts for the use of biogas as energy carrier .....	10
1.4 Challenges in heat use.....	12
<b>2 Basics about heat production and use</b> .....	<b>14</b>
2.1 Biogas combustion.....	14
2.2 Figures and conversion units of heat.....	15
2.3 Heat quality .....	15
2.4 Heat quantity and demand .....	16
2.5 Heat demand of digesters .....	17
2.6 Characteristics of biogas combustion engines.....	19
2.6.1 Gas-Otto engines .....	20
2.6.2 Gas-Pilot Injection engines.....	20
2.7 Concepts for combined heat and power production of biogas plants .....	22
<b>3 Heat use options of biogas plants</b> .....	<b>23</b>
3.1 Heating.....	24
3.1.1 District heating .....	24
3.1.2 Stables.....	30
3.1.3 Greenhouses.....	31
3.1.4 Aquaculture.....	33
3.1.5 Heat transport in containers .....	35
3.1.6 Heating for other purposes.....	38
3.2 Drying.....	38
3.2.1 Digestate and sewage sludge .....	42
3.2.2 Log wood, woodchips, and pellets.....	43
3.2.3 Agricultural products.....	45
3.3 Cooling.....	46
3.3.1 Overview of chillers .....	46
3.3.2 District cooling.....	48
3.3.3 Applications of cooling.....	50
3.4 Additional electricity production .....	50

---

3.4.1	<i>CRC systems</i> .....	51
3.4.2	<i>ORC systems</i> .....	52
3.4.3	<i>Kalina cycle</i> .....	55
3.4.4	<i>Stirling engine</i> .....	56
3.4.5	<i>Exhaust gas turbine</i> .....	57
<b>4</b>	<b>Innovative concepts for efficient biogas conversion</b> .....	<b>58</b>
4.1	Biogas pipelines and satellite CHP units .....	58
4.2	Biogas upgrading and grid injection of biomethane .....	60
4.3	Biomethane transport in containers .....	62
4.4	Biomethane use in transport .....	63
4.5	Biogas as load management and for grid stability .....	63
4.6	Biomethane and Power-to-Gas .....	64
<b>5</b>	<b>Guideline on heat use options</b> .....	<b>66</b>
<b>6</b>	<b>Conclusions</b> .....	<b>68</b>
	<b>Glossary and Abbreviations</b> .....	<b>69</b>
	<b>General conversion units</b> .....	<b>77</b>
	<b>References</b> .....	<b>79</b>

## ***Preface***

In Europe, as well as worldwide, the production and use of biogas is considerably increasing due to the growing demand for renewable energy as substitute for fossil energy carriers. Most agricultural and industrial biogas plants in Europe use biogas for electricity production in CHP (Combined Heat and Power) plants. However, in many cases the heat from the CHP unit is not used, but wasted. This is a result of the main focus of most support schemes on electricity production neglecting the efficient use of heat.

The inefficiency in energy use is a bottleneck in current biogas production, causing macroeconomic and microeconomic losses and challenges in the context of increasing land use competition. The BiogasHeat project addresses the problem of how to use the heat from biogas plants efficiently at the European, national and project level (Dzene et al. 2012). Thereby, a set of different policy, best practice, field test and project implementation measures are developed and used. The BiogasHeat project (IEE/11/025) is supported by the European Commission through the Intelligent Energy for Europe (IEE) programme operated by the Executive Agency for Competitiveness and Innovation (EACI).

As a major output of the BiogasHeat project, this handbook on “Sustainable Heat Use of Biogas Plants” was elaborated in order to provide an overview of different options for heat use of biogas CHP units. The handbook addresses current and future biogas plant operators as well as other interested stakeholders such as policy makers, investors and students working in the field of biogas. It provides general information on the characteristics of heat produced in biogas plants and focuses on general technical solutions for the efficient use of heat.

Complementary to the handbook, the report on “Good Practice Examples for Efficient Use of Heat from Biogas Plants” (Ramauskaite et al. 2012) presents selected concepts and examples of existing biogas plants that already use waste heat. Furthermore, information about economics and costs are also available in other reports developed by the BiogasHeat project and thus not included in this handbook. All reports are available at the BiogasHeat website ([www.biogasheat.org](http://www.biogasheat.org)).

Various sources and references have been used for the elaboration of this handbook. Thereby, mainly German literature was used, since Germany has currently the most advanced biogas sector in Europe. The authors tried to generalize facts and figures, so that they can be used in whole Europe. However, still some of them are country or region-specific.

Furthermore, standardised units and abbreviations, which are commonly used at European level, were applied. Details on conversion units are given at the end of the handbook. In the English version of the handbook, the decimal sign is a point (e.g. 12.03 Euro means 12 Euro and 3 Cent), and the thousand separator is a comma (e.g. 1,300 is one thousand three hundred).

As the target countries of the BiogasHeat project are Austria, Croatia, Czech Republic, Denmark, Germany, Italy, Latvia, Poland and Romania, the handbook is translated by the BiogasHeat partners into corresponding languages.



# 1 Introduction

The number of biogas plants worldwide increased considerably over the past few years. Many countries have developed modern biogas technologies and competitive national biogas markets throughout decades of intensive research and technical development (Al Seadi et al. 2008). This was achieved with the help of substantial governmental and public support. Today, energy from biogas is contributing towards the objective of national energy security and greenhouse gas mitigation in many countries. The European biogas sector accounts for thousands of biogas installations. Countries like Germany, Austria, Denmark, Sweden, Czech Republic, Italy and The Netherlands are among the technical forerunners, with the highest number of modern biogas plants. The focus of most of the plants is to maximise the electrical output from biogas in CHP units. However, in many cases the heat from CHP units is only partly used, or wasted. This inefficiency in energy use is a bottleneck in current biogas production, causing macroeconomic and microeconomic losses and challenges in the context of overall increasing land use competition.

## 1.1 Biogas production

Biogas is produced by anaerobic digestion (AD). AD is a biochemical process in which various types of anaerobic microorganisms (bacteria) decompose complex organic matter (biomass) into smaller compounds, in the absence of oxygen. The process of AD is common to many natural environments such as in marine water sediments, stomach of ruminants or in peat bogs. Also in biogas plants organic input material, which is called feedstock, is anaerobically digested in order to decompose it into the two main products biogas and digestate. In most biogas plants, several feedstock mixtures are simultaneously used in order to stabilize the process to optimise biogas production. This is called co-digestion. Suitable feedstock for AD includes a large range of biomass materials, preferably consisting of easily decomposable material. This includes fats, oils, sugars, and starch. Also cellulose is easily decomposable, whereas lignin, a major compound of wood, is difficult to decompose by AD. Typical feedstock for biogas plants can be of plant and animal origin.

- Animal excrements (manure, slurry, dung)
- Agricultural residues and by-products
- Organic wastes from food and agro industries
- Organic wastes from biomaterial industries (e.g. pulp and paper, pharmaceuticals)
- Organic fraction of municipal solid waste
- Food waste from catering services
- Sewage sludge from wastewater treatment plants
- Dedicated energy crops (e.g. maize, sugar beet, grass)

The type of the feedstock influences the AD process and the final composition of the produced biogas. Biogas consists mainly of methane ( $\text{CH}_4$ , 40-80%) and carbon dioxide ( $\text{CO}_2$ , 15-45%) and of smaller amounts of hydrogen sulphide ( $\text{H}_2\text{S}$ ), ammonia ( $\text{NH}_3$ ), nitrogen gas ( $\text{N}_2$ ), and other compounds. Furthermore, biogas is normally saturated with water vapour ( $\text{H}_2\text{O}$ ).

The desired compound is energy rich methane since this can be converted in a CHP unit into electrical energy and heat. The methane yield is one of the most important characteristics of the used feedstock in the AD process. Yields of selected feedstock are shown in Table 1. The type and the methane yields of feedstock highly influence the profitability of a biogas plant.

Besides the feedstock type, also other factors such as the design of the digestion systems, digester temperature, retention time, and organic load influence the composition of the biogas.

**Table 1: Methane yields of selected feedstock (Data from BMU 2012)**

Feedstock	CH <sub>4</sub> yield [m <sup>3</sup> /t fresh feedstock]	Feedstock	CH <sub>4</sub> yield [m <sup>3</sup> /t fresh feedstock]
Frying oil and fats	562	Potato peels	66
Glycerine	421	Press cake from sugar production	64
Casein	392	Sugar beet shavings	64
Lactose	378	Legumes (whole crop)	63
Skimmed milk dry	363	Spent grains (fresh/pressed)	61
Baking waste	344	Potato pulp from starch production	61
Grain maize	324	Medical and spice plants (rejected)	58
Cereal grain kernels	320	Food leftovers	57
Rapeseed cake	317	Cut flowers (rejected)	55
Whey, low sugar, dry	298	Fodder beet	52
Rapeseed meal	274	Small beet pieces (from sugar processing)	50
Cereal waste	272	Sugar beet leaf with sugar beet parts	46
Bran	270	Rennet whey	44
Old bread	254	Flotation fats	43
Waste from cereal processing	254	Green cuttings from private/public gardens and park maintenance	43
Corn cob mix (CCM)	242	Grass from roadways maintenance	43
Grain dust	172	Acid whey	42
Molasses from beet sugar production	166	Vegetables (rejected)	40
Cobs, husks, kernels of corn	148	Fodder beet leaf	38
Corn (whole crop)	106	Skimmed milk fresh	33
Cereals (whole crop)	103	Contents of rumen	33
Grass including ley grass	100	Buttermilk fresh	32
Potatoes	92	Potato haulm	30
Potatoes (rejected)	92	Guts (pigs)	27
Curd cheese	92	Waste from vegetable processing	26
Lactose molasses	91	Cereal vinasse except from alcohol production	22
Animal blood	83	Acid whey fresh	20
Flotation sludge	81	Cereal vinasse from alcohol production	18
Sorghum (whole crop)	80	Potato vinasse except from alcohol production	18
Sudan grass	80	Fresh sweet whey	18
Ryegrass	79	Whey	18
Sugar beet	75	Potato vinasse from alcohol production	17
Forage rye (whole crop)	72	Grease separator contents	15
Milk	70	Water from potato starch production	11

Feedstock	CH <sub>4</sub> yield [m <sup>3</sup> /t fresh feedstock]	Feedstock	CH <sub>4</sub> yield [m <sup>3</sup> /t fresh feedstock]
Lactose molasses low protein	69	Potato waste water from starch production	11
Sunflower (whole crop)	67	Potato processing water from starch production	3
Potatoes (pulped, medium starch content)	66	-	-

The composition of biogas is an important feature which influences the combustion of biogas in the CHP unit and thus the composition and temperature of the exhaust gases. This influences the quantity and quality of heat that can be used in a heat concept.

Furthermore, the concept of the biogas plant is characterised by the temperature level of the digesters, which are usually heated with a fraction of the heat from the CHP unit in order to allow bacteria fast decomposition of the material. Digesters of biogas plants are typically categorised into the following temperature levels:

- **Psychrophilic:** below 25°C
- **Mesophilic:** 25°C – 45°C
- **Thermophilic:** 45°C – 70°C

Thereby, some biogas plants with several digesters in series often use different temperature levels in the digesters. The digester temperature has direct influence on the heat concept, since the warmer the digester is, the less heat is available for other uses. On the other hand, the biogas yield is increased if higher temperatures up to a certain maximum are applied. The optimum temperature has to be defined. The selection of the temperature level is influenced by the used feedstock, plant design, desired retention time, decomposition rate, and the heat concept. The most important factor for the biogas plant operator for selecting the temperature level is usually the AD process stability.

## 1.2 Biogas plant concepts

The energy output, and thus the heat output of a biogas plant, is influenced by the overall biogas plant concept. The plant concept has an effect on the different options of the utilisation of waste heat from CHP units. Biogas plant concepts can be characterized by the following aspects.

- **Main objective:** Energy production (electricity, heat), waste treatment, biomethane injection to the natural gas grid, energy storage, load management, nutrient production and upgrading
- **Plant size:** Average installed electric capacities of the plants in Europe are approximately 400 to 500 kW<sub>el</sub>, but sizes range from 1-2 kW for the use of household wastes (as applied in many developing countries) to multi-megawatt biogas plants.
- **Technology:** Dry / wet digestion, batch / continuous digestion
- **Business model:** Agricultural, industrial, household, wastewater treatment, waste treatment biogas plants
- **Feedstock type:** Dedicated energy crops, agricultural wastes and residues, food waste, industrial waste, sewage sludge

The **main objective** of biogas plants in Europe is currently the production of renewable energy and more specifically the production of electricity. This is due to the main focus of most public support schemes for biogas plants on electricity production (electricity feed-in tariff) which often neglects the efficient use of heat. These biogas plants are mainly

addressed by the BiogasHeat project (Dzene et al. 2012). However, in order to increase the efficiency and sustainability of these biogas plants, the major objective should be the maximisation of the energy use. Therefore, policies and legislation have to be adjusted to maximise the efficiency, but at the same time the economic feasibility of the project has to be ensured. Energy efficiency of biogas plants can be achieved through different measures, such as the use of the waste heat from CHP units in a dedicated heat concept, or through the upgrading of biogas to biomethane (natural gas quality of > 95% methane) - which can be injected into the natural gas grid. The advantage of grid injection is that the biomethane can be combusted locally where the heating demand occurs. However this technology is still very expensive and usually profitable on a large scale only. Incentives and suitable legislation is often missing. Furthermore, plants have to be close to the natural gas grid. Another important objective of biogas plants is their ability to stabilize power grids by storing energy and thus to contribute to an active load management in a smart electricity grid, which is explained later in the handbook. The main objective of waste treatment biogas plants is usually sustainable waste management (Rutz et al. 2011; Rutz et al 2012). Often the main source of income of these business models is tipping fees for waste treatment and only to a smaller extent through the sale of energy (electricity and/or heat). Several decades ago, a major objective during the initial phase of biogas development in Germany was the recycling and upgrading of agricultural nutrients in organic farming systems.

The average **plant size** of a typical biogas plant in Germany and most other European countries is approximately 450 kW<sub>el</sub>. However, the plant sizes range from 1-2 kW (3-4 m<sup>3</sup> digesters) biogas plants for the use of household wastes, as they are frequently applied in many developing countries, to sophisticated multi-megawatt biogas plants. The size of the plant influences the quantity and availability of heat production. In a biogas plant which has an engine based CHP unit, the efficiency reaches up to 90%. Thereof it produces about 35% electricity and 65% heat.

In general, heat is needed for digester heating in all modern biogas plants in Europe. The **technology** influences the amount of the needed heat, since temperature level and insulation are different. Usually continuous heat supply is required for all biogas plants, for continuous but also for batch reactors, for dry and for wet digestion. The heat supply is largely influenced by seasonal ambient temperature. Good insulation of the digesters is a precondition for an efficient and stable process.

Typically the operation of biogas plants is integrated in existing businesses, such as farms, industrial companies or waste treatment companies. The **type of business** influences the main objectives of the biogas plant as well as the potential options for heat use. In agricultural biogas plants, the heat is frequently used for heating stables, drying woodchips, heating houses and cooling milk. In waste treatment plants heat can be used for sanitation, hygienisation and cleaning purposes. A typical use of heat in industrial plants is process heat, but this is limited by heat quality as often higher temperatures are needed.

As it was already described in chapter 1.1, the **feedstock type** influences the biogas composition and thus the quantity and quality of available heat.

### **1.3 Concepts for the use of biogas as energy carrier**

Biogas can be converted into **heat**, **mechanical energy**, and **electromagnetic energy** (light). It can be furthermore used as a **chemical compound**. There exist many different options for the use of biogas ranging from very small applications to technically sophisticated installations.

- **Lighting:** in gas lamps
- **Heating:** in biogas burners, boilers, and gas stoves
- **Drying:** as a special form of heat use in charge driers, belt driers, feed-and-turn driers as well as in sorptive thermal storage systems

- **Cooling:** in absorption chillers
- **Electricity:** in gas engines (Pilot Injection Engines, Gas-Otto Engines), fuel cells, micro-gas turbines, Rankine Cycles (CRC, ORC), Kalina cycles, Stirling engines, exhaust gas turbines
- **Transport:** in Compressed Natural Gas Vehicles as biomethane
- **Energy storage:** in dedicated biogas storage systems (low and high pressure; liquefied) or as biomethane in the natural gas grid in order to balance electricity and heat loads
- **Natural gas substitute:** upgrading to biomethane followed by injection into the natural gas grid



Figure 1: Biogas burner in Austria (Source: Rutz)

Figure 2: One of the simplest applications for biogas: biogas stove for cooking in Mali (Source: Rutz)

Various simple technologies easily allow using biogas in **gas stoves** for cooking (Figure 2) or in **gas lamps** for light. This is frequently used in household-scale biogas plants in developing countries. These technologies are however not further discussed in this handbook.

Sometimes **gas burners and boilers** (Figure 1, Figure 16) are applied to produce heat only. These gas burners can be used, for example, to heat the digesters of biogas upgrading plants which feed the upgraded biomethane into the natural gas grid or which supply gas filling stations for vehicles. For upgrading plants, also so called low calorific value (LCV) gas burners (Figure 4) can be used that burn a mixture of the exhaust gas from the upgrading process and biogas in order to produce heat for the digester heating. These burners are able to burn gases with very low methane contents of 5 to 30 vol.% methane. Gas burners and boilers can be used as back-up systems for upgrading plants.

The main use of biogas in most European biogas plants is the **CHP generation**. Before its combustion, the produced biogas is dried and in many cases cleaned, since most gas engines have maximum limits for the content of hydrogen sulphide, halogenated hydrocarbons and siloxanes. An engine based CHP unit has an efficiency of up to 90% and produces thereof about 35% electricity and 65% heat. In most plants a smaller fraction of the generated heat is needed (20-40%) for the digester heating system, but the larger part (60-80%) is considered as “waste” heat that is often not used for further processes. This heat could be used for **additional electricity** production in e.g. Stirling engines, Organic Rankine

Cycles (ORC), and Clausius-Rankine-Cycles (CRC), or for other purposes such as heating, drying and cooling. These options will be presented in-depth in this handbook.

CHP units usually include combustion engines such as Gas-Otto and Gas-Pilot Injection engines. Gas-Pilot Injection engines usually need 2-5% diesel or oil for ignition in addition to the biogas, whereas Gas-Otto engines run purely on biogas. More details on combustion engines can be found in chapter 2.7.

Also **fuel cells** (Figure 3) and **micro-gas turbines** can produce combined heat and power. However, these are still only niche applications and thus not the main focus of this handbook.

The use of biomethane in vehicles for **transport** is another option for using biogas. In this case, biogas must be purified and upgraded to natural gas quality. As mentioned earlier in this handbook, biogas upgrading is done by means of relatively expensive technology and is thus currently only feasible for larger plants. Although the energy efficiency of the used biomethane in vehicles is generally very low (as low as for common fuels use in vehicles), this option is promising, since alternatives for fuels in the transport sector are limited.



**Figure 3: Molten Carbonate Fuel Cell (MCFC) for biogas in Leonberg, Germany (Source: Rutz)**



**Figure 4: Low calorific value (LCV) burner of a biogas upgrading plant for digester heating in Aiterhofen, Germany (Source: Rutz)**

In addition to the different technologies for biogas use, an increasingly important aspect and advantage in comparison to other renewable energy sources is the good **storability of biogas** and biomethane. Being a natural gas substitute, it can thus contribute to increase power grid stability and be used as a load management tool. Finally, another potential use of biogas, which is however not considered in this handbook, is as a **chemical compound** in biorefineries.

#### **1.4 Challenges in heat use**

The use of heat from biogas plants faces different challenges, influenced by plant characteristics. Often biogas plants are located in remote areas with no heat demand. Furthermore, the amount and quality of produced heat is often not sufficient for larger industries. Therefore, niches have to be identified in which the heat could be valorised in the

most efficient and profitable way. The following list shows important challenges which typically characterize biogas plants.

- **Seasonality:** Less heat is needed for heating the digesters in summer. Furthermore, certain heating applications, e.g. of buildings, are only needed in winter. Thus, there is often a heat surplus in summer.
- **Remoteness:** Especially agricultural biogas plants are often situated in remote rural areas where no heat consumers (e.g. small industries, public buildings) can be identified.
- **Heat quality and quantity:** The installed capacity of typical agricultural biogas plants in Europe is about 500 kW<sub>th</sub>, which is too small for the use of heat by larger industries. Some industries require higher temperatures than the ones that can be provided by a biogas plant.
- **Economic risks:** Biogas plant operators who “depend” on external heat consumers may face economic risks in case of changing demand. Long-term contracts can help to mitigate this risk.
- **High costs:** Several options for using waste heat require additional equipment with high investment costs, for example the installation of ORC modules or the set-up of micro-heating grids.
- **Public acceptance and support:** The set-up of new micro-heating-grids is only possible if the heat demand is ensured, meaning that enough customers are willing to get connected. Furthermore, local administrations need to be supportive to allow the construction of micro-heating-grids.
- **Fossil fuel prices:** The use of waste heat from biogas plants has to be competitive with the prices of fossil fuels and other renewable energy sources.

## 2 Basics about heat production and use

Heat is defined in **thermodynamics** as energy transferred from one system to another by thermal interaction. It is a function of process in contrast to a function of state such as temperature or volume. It describes the transition of a system from an equilibrium state to another equilibrium state. Thereby the system is characterized by dedicated system boundaries. Heat flows spontaneously always from a high to a low temperature system. The term "heat" is often also expressed as "heat flow" and "heat transfer". Heat transfer can occur by conduction, radiation, convection, mass transfer, and by chemical reactions.

A differentiation between **sensible heat** and **latent heat** has to be made. Sensible heat is directly measurable through the change in temperature. Latent heat is the heat released or absorbed by a body or a thermodynamic system during a process that occurs without a change in temperature. A typical example is a change of state of matter, such as the phase transition from ice (solid phase) to water (liquid phase).

Applied to the heat of a CHP unit in a biogas plant, heat can be characterized e.g. by a certain volume of water (or other substance) with high temperature. This heat can be used in different ways, whereas the temperature of the water is decreased to a lower level.

### 2.1 Biogas combustion

The heat of combustion ( $\Delta H^0$ ) (Equation 1) is the energy released as heat when a compound (biogas or biomethane) undergoes complete combustion with oxygen under standard conditions. The chemical equation is methane reacting with oxygen to form carbon dioxide, water and heat.

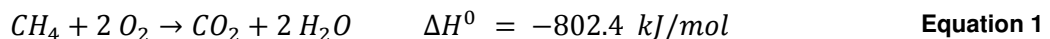

In this combustion reaction, -802.4 kJ/mol is released if pure methane is combusted. This is equivalent to about 35.89 MJ/Nm<sup>3</sup> (H<sub>i</sub>) or about 10 kWh. Since biogas and biomethane do not consist of pure methane (40-80% for biogas and about 95% for biomethane), the energy content is lower. The amount of heat released during the combustion process is also called **heating value**.

In applied combustion systems, fuels are often characterised by lower and higher heating values. They depend on the chemical composition of the fuel.

The **lower heating value** (LHV), also called net inferior heating value (H<sub>i</sub>), net calorific value (NCV) or lower calorific value (LCV), assumes that the energy for vaporizing the water content of the fuel is not usable and thus not included in the figure. The LHV can be obtained by subtracting the heat of vaporization of the water vapour from the higher heating value. Calculations assume that the water component of a combustion process is in vapour state at the end of combustion, as opposed to the HHV which assumes that all of the water in a combustion process is in a liquid state after a combustion process. The LHV of biogas depends on the methane content and on the gas quality. It is in the range between 21.5 to 23.5 MJ, or 5.5 to 6.0 kWh/Nm<sup>3</sup>.

The **higher heating value** (HHV), also called superior heating value (H<sub>s</sub>), gross energy value, upper heating value, gross calorific value (GCV) or higher calorific value (HCV), is the total energy content of the fuel. It is determined by bringing all the products of combustion back to the original pre-combustion temperature (often 25°C), and in particular condensing any vapour produced. The HHV assumes that all water is in the liquid state at the end of the combustion.



The higher heating value exceeds the lower heating value of natural gas by about 11%.

## 2.2 Figures and conversion units of heat

The mathematical symbol of heat is **Q** and the SI unit is the **joule (J)**. In many applied fields in engineering the British Thermal Unit (BTU), the tonne of oil equivalent (toe), and the calorie are used. The mathematical symbol for the rate of heat transfer (capacity) is **Q̇** and the standard unit **watt (W)**, defined as joules per second. Watt is also the most frequently used unit in the field of the biogas sector.

- 1 J = 1 Ws = 1/3,600 Wh
- 1 Wh = 3,600 Ws = 3,600 J
- 1 toe = 11,630 kWh = 41.87 GJ
- 1 BTU = 1,055 J

The capacity of a biogas plant is usually expressed in **kW** or MW (kilo or mega Watt) for the total capacity, **kW<sub>el</sub>** for the electrical capacity and **kW<sub>th</sub>** for the thermal capacity. The produced energy is expressed as **kWh** or MWh (kilo Watt per hour). The actual energy output of a biogas plant is usually expressed as **kWh/yr** (kilo Watt hours per year). This is based on the number of hours of a regular year, being **8,760 hours per year** (yr). For the size of typical biogas plants usually the SI prefixes kilo (10<sup>3</sup>), mega (10<sup>6</sup>) and giga (10<sup>9</sup>) are used.

Heat can be either measured by a **calorimeter** or **calculated** by using other figures, such as by volume, mass, temperature, and heat capacity. For the use of heat in applied energy systems, such as for residential heating, a **heat meter** is usually used. It is a device which measures the thermal energy from a source (e.g. biogas CHP unit) by measuring the flow rate of the heat transfer fluid (e.g. water) and the change in its temperature ( $\Delta T$ ) between the flow and return pipes.

An important figure for CHP units is the **power-to-heat ratio** which is the relation of electrical energy to useful thermal energy (Directive 2004/8/EC). A high figure characterizes a high electrical output. The figures of typical CHP units are between 0.4 and 0.9.

The following figures are useful for the energy calculation and measurement of biogas plants:

- Energy content of 1 kg biomethane: 50 MJ
- Energy content of 1 Nm<sup>3</sup> biomethane: 35.5 MJ or about 9.97 kWh
- Biomethane content of 1 Nm<sup>3</sup> biogas: 0.45-0.75 Nm<sup>3</sup>
- Energy content of 1 Nm<sup>3</sup> biogas: 5-7.5 kWh
- Electrical output of 1 Nm<sup>3</sup> biogas: 1.5-3 kWh<sub>el</sub>
- Density of 1 Nm<sup>3</sup> biomethane: 0.72 kg/Nm<sup>3</sup>

Another figure which is useful for illustrating the energy content of biogas is the energy equivalent of 1 m<sup>3</sup> biogas to about 0.6 l of domestic heating oil. Further details on conversion units are shown in the chapter "General conversion units" at the end of this handbook.

## 2.3 Heat quality

Besides the amount of energy (quantity), the characteristics of the type of energy (quality) are important when developing concepts for the use of energy. One important parameter that characterizes the quality of energy is the transferability of one energy form to another energy form. Generally, electricity is considered of higher quality than heat, since electricity can easily be transported and used for different purposes such as the production of mechanical energy or heat, electromagnetics, etc.

In thermodynamics often the term **exergy** is used. It describes the maximum energy part of a system that can be converted into useful work, if the system is in equilibrium with the environment.

Furthermore, heat is characterized by the temperature level and by the quantity of heat. For the development of waste heat concepts, the temperature and the amount of heat are important, since the heat user always needs a certain minimum level of both figures. The temperature of the waste heat source needs to be always higher than the temperature of the heat sink. The magnitude of the temperature difference between the heat source and sink is an important determinant of the quality of waste heat. Generally, it can be said that the higher the temperature and the amount of energy (entropy), the higher is the quality. With higher waste heat temperatures, more opportunities for its use exist. Examples for minimum temperatures of different uses are:

- **Hot water supply:** 50-80 °C
- **Residential heating:** 50-80 °C
- **Rankine cycles (ORC, CRC):** 60-565 °C
- **Dryer** for agricultural products: 60-150 °C

These examples are typical for the use of waste heat from biogas plants. Since the exhaust gas temperature of CHP units in biogas plants is typically about 450-520 °C, the use of waste heat from biogas plants is limited. The temperatures from engine cooling and the lubricant cycle are even lower, as described in chapter 2.6. For industries that require high temperatures and large amounts of energy, this waste heat is usually not enough and temperatures are too low.

## **2.4 Heat quantity and demand**

Today, electrical capacities of biogas plants range from 50 kW<sub>el</sub> up to 30 MW<sub>el</sub>. Capacities of typical agricultural biogas plants in Europe using CHP units are in the range of about 500 kW<sub>el</sub>, whereas about 550-600 kW<sub>th</sub> waste heat is produced. Thereof about 500 kW<sub>th</sub> would be available for commercial heat use. About 25% of the produced heat is required to heat the digesters under central European climatic conditions (Figure 6). Assuming about 8,000 operational hours per year, the total energy of a 500 kW<sub>th</sub> biogas plant would be 4,000 MWh<sub>th</sub>.

One of the simplest and most frequent heat uses for the consumption of waste heat is heating and domestic hot water (DHW) supply of households. Thus, the following example shows the average net energy consumption per person in Germany (based on calculations from Paeger 2012):

- Net energy consumption for heating and DHW per person in households: 20.2 kWh/day or 7,373 kWh/yr
- Net energy consumption for heating per person in households: 17 kWh/day or 6,205 kWh/yr
- Net energy consumption for heating per person in households (per m<sup>2</sup> living area): 155 kWh/yr/m<sup>2</sup>
- Net energy consumption for DHW per person in households: 3.2 kWh/day or 1,168 kWh/yr

Considering the net energy consumption for heating and hot water per person of 7,373 kWh/yr, the energy production of 4,000 MWh<sub>th</sub> in a 500 kW<sub>th</sub> biogas plant would be sufficient for the annual energy needs of 543 persons. This of course is only a rough estimation based on average numbers. Other factors, such as variable seasonal heat demand due to different climatic conditions in winter and summer need to be considered, too. This seasonality in heat demand is a major challenge for waste heat concepts for residential heating.

## 2.5 Heat demand of digesters

As described in previous chapters, digesters need to be heated in order to guarantee a stable and efficient process. Common digester temperatures range from 38°C to 44°C for typical mesophilic biogas plants, depending on the feedstock and on the overall process. The digesters can be heated by different technologies, e.g. by heating pipes along the fermenter walls, or by pumping the digestate through a heat exchanger.

For heat concepts, the heat demand of the digesters is important, since this influences the heat quantity available for further purposes. The heat demand of the digester is influenced by the ambient temperature and thus by climatic conditions. Furthermore, in waste treatment plants, heat may be also needed for hygienisation of the feedstock.

When assessing the heat demand of a biogas plant, the demand of the start-up phase has to be distinguished from the heat demand for continuous operation. The initial heat demand ( $Q_{start}$ ) is shown in Equation 2 and influenced by the specific characteristics of the feedstock (heat capacity  $c$ ), the amount of the feedstock ( $m$ ) and the difference of the feedstock temperature ( $\Delta T$ ). Also in the start-up phase, some heat is lost through the digester surfaces.

$$Q_{start} = (c \times m \times \Delta T \times t) + Q_{lost} \quad \text{Equation 2}$$

$Q_{start}$	Heat needed for the start of the AD process [kWh]
$c$	Heat capacity of feedstock [J/kg K]
$m$	Mass [t]
$\Delta T$	Change in temperature of feedstock temperature before and after feeding into the digester [K]
$t$	Time (hours)
$Q_{lost}$	Heat losses of through digester surfaces [kWh]

After the start-up phase the continuous operation starts. The heat demand ( $Q_{operation}$ ) is generally the sum of the lost heat through the digester walls ( $Q_{lost}$ ) and the heat loss due to the output of the digestate ( $Q_{digestate}$ ).

To decrease the heat demand of the digesters good insulation (Figure 7) is needed. The walls of the digester are usually insulated with hard foam panels. The lost heat is determined by the surface area, the heat transfer coefficient and the change in temperature. (Equation 3 Equation 4). A simplified scheme for an insulated digester wall and the temperature profile is shown in Figure 5. The digester floor should be insulated as well. The cover foil of the digester is often not insulated. If the digester is covered by a concrete ceiling, it can be also insulated. The total lost heat ( $Q_{operation}$ ) is the sum of all losses from the different digester surfaces and the digestate output (Equation 4). To calculate the insulation losses the heat transfer coefficient has to be determined (Equation 5).

In order to increase the heat output, heat recovery systems, which also use the heat from the digestate leaving the digester, can be installed. The two most efficient measures to decrease heat losses is insulation of all digester surfaces (including the floor, the walls and the cover) and heat recovery from the digestate.

$$Q_{lost} = A \times U \times \Delta T \times t \tag{Equation 3}$$

$$Q_{operation} = Q_{lost-wall} + Q_{lost-floor} + Q_{lost-cover} + Q_{digestate} \tag{Equation 4}$$

$$U = \frac{1}{\frac{1}{h_i} + \frac{d_1}{k_1} + \frac{d_2}{k_2} + \frac{1}{h_a}} \tag{Equation 5}$$

$Q_{lost}$  Lost heat through the digester surfaces (differentiated into losses of wall, floor, and cover) [kWh]

$Q_{operation}$  Lost heat through digester surfaces and digestate output [kWh]

$Q_{digestate}$  Lost heat by digestate output [kWh]

$A$  Heat transfer surface area [m<sup>2</sup>]

$U$  Heat transfer coefficient [W/m<sup>2</sup>K]

$\Delta T$  Change in temperature (inside-outside) [K]

$t$  Time (hours)

$h_i$  Convection heat transfer coefficient inside the digester (W/m<sup>2</sup>K)

$h_a$  Convection heat transfer coefficient outside the digester (W/m<sup>2</sup>K)

$d_1$  Thickness of layer 1

$d_2$  Thickness of layer 2

$k_1$  Thermal conductivity of the 1<sup>st</sup> layer (W/mK)

$k_2$  Thermal conductivity of the 2<sup>nd</sup> layer (W/mK)

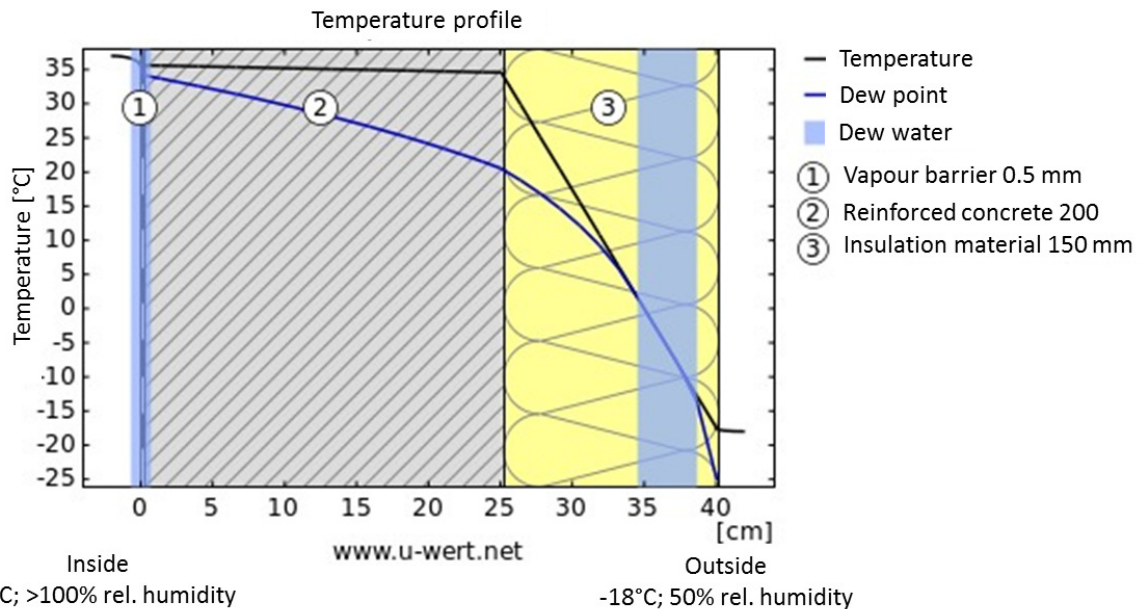
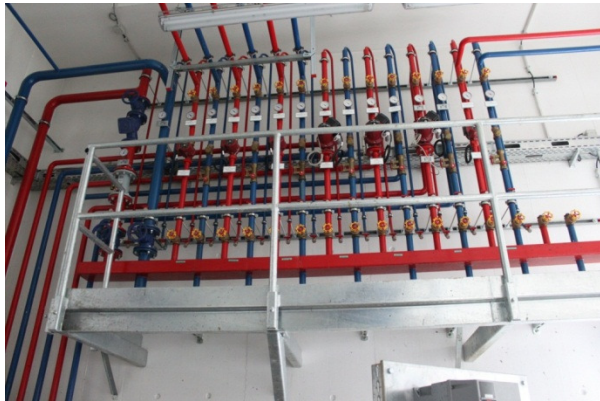

**Figure 5: Schematic graph showing the wall of a digester including a temperature profile in cold winter (-18°C) (Source: own data; adapted from www.u-wert.net)**

As the digester heating is influenced by many factors, including climatic details, it is difficult to calculate exact figures for the heat demand.

For a rough estimation of the needed heat for digester heating, often the following rules of thumb are used:

- In a CHP unit about 35% electricity and 65% heat are produced
- The heating of digesters needs approximately 25% of the heat capacity of the CHP unit
- The power-to-heat ratio of biogas CHP units (relation of electrical energy to useful thermal energy) is usually between 0.4 and 0.9 and often about 0.85



**Figure 6: Heat distribution system of a biogas plant for digester heating in Aiterhofen, Germany (Source: Rutz)**



**Figure 7: Insulation (orange panels) of digesters in Reichenkirchen, Germany (Source: Rutz)**

## 2.6 Characteristics of biogas combustion engines

The dominant use of biogas in Europe is electricity production in internal combustion engines, also called gas engines. Since energy conversion in these engines always goes along with heat production, all gas engines are defined here as CHP units, even if the heat is not used.

Several different gas engines exist, which are typically categorized into Gas-Otto engines and Gas-Pilot Injection engines. Details on these engines are described in the subsequent chapters and an overview of some characteristics is shown in Table 2. All biogas engines have to face the challenge of variable gas quality. Furthermore, the methane content is relatively low, reaching levels that are even below 45% of the total gas volume. The capacities of gas engines may range between 10 kW<sub>el</sub> and 5 MW<sub>el</sub>. Several manufacturers offer gas engines for biogas applications such as for example Schnell, 2G, Rolls-Royce, Kawasaki, MTU, GE Energy (Jenbacher), Caterpillar, Perkins, MWM, Cummins, Wärtsilä, Dresser-Waukesha, Guascor or MAN.

In a gas engine, the energy is converted into usable and non-usable energy. The following figures show that in total approximately 90% energy could be used (average numbers):

- 10% losses
- 35% mechanical energy (electricity)
- 55% usable heat

From the total produced heat, the following heat categories can be characterized. The largest share of available heat is from exhaust gases and from the engine cooling cycle.

- 1-3% lubrication cycle (engine lubricating oil): 80 - 90 °C
- 3-5% radiation losses
- 30-40% engine cooling (cooling water): 80 - 90 °C
- 50-60% exhaust gas: 460 - 550 °C

The heat availability of the engine **cooling and lubrication cycle** is usually constant and below 100 °C. This heat is usually used to heat **water** for different purposes. Due to its relative low temperature, no specific requirements for the water pipes on the resistance to higher pressure are needed.

The heat availability from the **exhaust gas** is influenced by the rate of fouling (deposit of impurities on the heat exchange surface) of the heat exchanger. Temperatures up to 550 °C can be measured in the exhaust gas stream. Such high temperatures require high pressure pipes due to vapour creation. Therefore, **thermic oils** are often used that remain liquid at high temperatures. However, due to lower thermal conductivity of thermal oils, generally larger heat exchangers are needed. The reduction of the exhaust gas temperature may lead to the formation of condensate in the exhaust gas system that may lead to corrosion. Therefore the specifications of the engine manufacturers have to be considered.

The **power rating** of a CHP unit is a specification defined by the manufacturer as a maximum power to be used with that device. This limit is usually set lower than the level where the device will be damaged to allow a margin of safety. However, it is also possible that with aging of the CHP unit, the maximum power output will decrease. Thus, the actual **electrical capacity** usually differs from the power rating of the manufacturer.

### 2.6.1 Gas-Otto engines

Gas-Otto engines (Figure 8) are specifically designed engines for the use of gases. They are based on the Otto principle and usually operated with high air surpluses in order to minimise carbon monoxide emissions.

The electric capacity of Gas-Otto engines ranges usually between 100 kW<sub>el</sub> and 1 MW<sub>el</sub> and can be used for biogas with methane contents higher than 45%. The electrical efficiency ranges between 34 and 40% and the average lifetime of Gas-Otto engines is about 60,000 hours. After a general overhaul of every 60,000 hours the lifetime can be extended. The lifetime generally depends very much on operation characteristics and on maintenance intervals.

### 2.6.2 Gas-Pilot Injection engines

Gas-Pilot Injection Engines (also called Pilot Injection Engine or Dual Fuel Engine) (Figure 9) are based on the diesel engine principle. As for Gas-Otto engines, also Gas-Pilot Injection engines are operated with high air surpluses. For their operation, up to 10% ignition diesel or oil is needed, which is directly injected into the combustion chamber whereas the biogas is injected together with the air. Generally the engines can be also operated only with diesel or oil. In some countries such as Germany it is required to use either biodiesel or vegetable oil as ignition fuel, in order to get feed-in tariffs. The use of fossil ignition fuels is not an eligible practice to get feed-in tariffs.

Typical use of Gas-Pilot Injection engines include installed capacities of up to 250 kW<sub>el</sub>. The electrical efficiency ranges between 30% and 40% and the average lifetime of a Gas-Pilot Injection engines is about 35,000 hours, after which the engine usually has to be replaced, as this is usually cheaper than a general overhaul.

Table 2: Selected characteristics of Gas-Otto engines and Gas-Pilot Injection engines (adapted from FNR 2010)

	Gas-Otto engines	Gas-Pilot Injection engines
<b>Installed electric capacity</b>	Can be higher than 1 MW, capacities of <100 kW are found only rarely	< 340 kW
<b>Methane content</b>	> 45 %	Also suitable for biogas with very low CH <sub>4</sub> content
<b>Electrical efficiency</b>	34-42%	30-44%
<b>Lifetime</b>	60,000 hours	35,000 hours
<b>Additional fuel</b>	none	1-5% ignition oil
<b>Suitability</b>	rather for larger biogas plants	rather for smaller biogas plants
<b>Advantages</b>	<ul style="list-style-type: none"> <li>+ specifically designed for gases</li> <li>+ good exhaust gas emission values</li> <li>+ low maintenance efforts needed</li> <li>+ total efficiency higher than gas-pilot injection engines</li> </ul>	<ul style="list-style-type: none"> <li>+ lower investment costs</li> <li>+ higher el. efficiency than Gas-Otto engines</li> <li>+ lower gas quality requirements</li> </ul>
<b>Disadvantages</b>	<ul style="list-style-type: none"> <li>- investment costs are slightly higher than for gas-pilot injection engines</li> <li>- higher costs due to general lower production numbers of engines</li> <li>- Smaller el. efficiencies than gas-pilot injection engines</li> </ul>	<ul style="list-style-type: none"> <li>- higher maintenance efforts needed</li> <li>- total efficiency smaller than for Gas-Otto engines</li> <li>- Additional fuel (oil) is needed</li> <li>- higher exhaust gas emission values (NOx)</li> </ul>

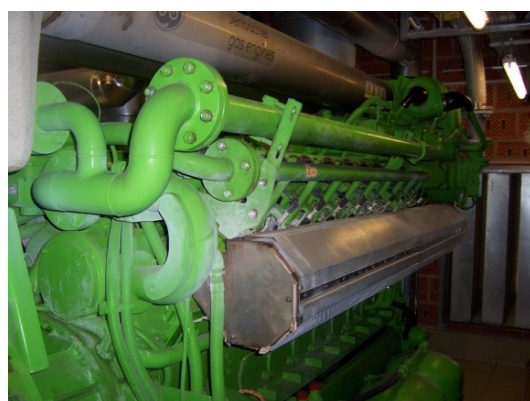

Figure 8: Gas-Otto engine in a biogas plant in Germany (Source: Rutz)

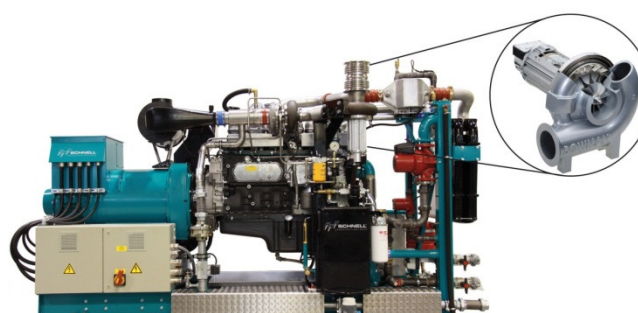

Figure 9: Dual fuel engine (Gas-Pilot Injection engine) of 235 kW<sub>el</sub> capacity with an integrated exhaust gas turbine of 30 kW<sub>el</sub> capacity (Source: Schnell Motoren AG)

## **2.7 Concepts for combined heat and power production of biogas plants**

Most biogas plant operators try to maximise the operational duration of their CHP units. Full load operation of more than 8,000 hours per year is possible, but usually it is a little bit less. The reason for maximizing operational duration is due to most support systems, such as feed-in tariffs. They usually provide incentives for the amount of produced electricity.

In other concepts and if suitable support schemes would be introduced, the CHP units of biogas plants could also operate on an electricity or heat demand driven basis.

In a system which is dominated by the **electricity demand**, the power of a biogas CHP unit could be used for **load management**.

In a system which is dominated by **heat demand**, the heat of a biogas CHP unit would be adjusted to the actual heat demand. Such systems, however, are not common, since they are not supported by incentives. Furthermore, heat driven biogas plants are related to several challenges, including e.g. seasonality of heat demand for residential heating.

A general limitation of demand-driven electricity and heat production is the good, but limited storage capacity of biogas. In case of injection of upgraded biogas (biomethane) into the natural gas grid, the storage problem of biogas plants is solved, since the natural gas grid has a very large storage capacity.

In summary, most CHP units of biogas plants try to maximise electricity production. For other CHP units, e.g. for small-scale CHP units in households running on natural gas or biomethane the CHP unit is usually driven by heat demand.



### 3 Heat use options of biogas plants

The use of waste heat from CHP units is a crucial factor for the economic and environmental performance of biogas plants. It has to be economically and technically feasible. If the application of a sound heat concept is not possible, other solutions such as upgrading and biomethane grid injection or the installation of biogas pipelines has to be considered. In many cases it is better to give up plans for a biogas plant project if no acceptable concept for heat use can be developed.

If planned well and enough in advance, however, heat concepts can be developed for most biogas plants. The more flexible the framework conditions are, the more options for the use of waste heat are available. These framework conditions include e.g. the location of the plant, potentially interested heat consumers, legal issues, liquidity, etc.

The main product of biogas plants is power which is usually fed into the electricity network. As Figure 10 shows, in very few cases, CO<sub>2</sub> can be used, e.g. for improved plant growth in greenhouses, for algae production or for Power-to-Gas plants (chapter 4.6). The main challenge is the sustainable use of the heat. It can generally be used directly for heating, but also for additional power production, cooling, or for drying. These options are discussed in the following chapters.

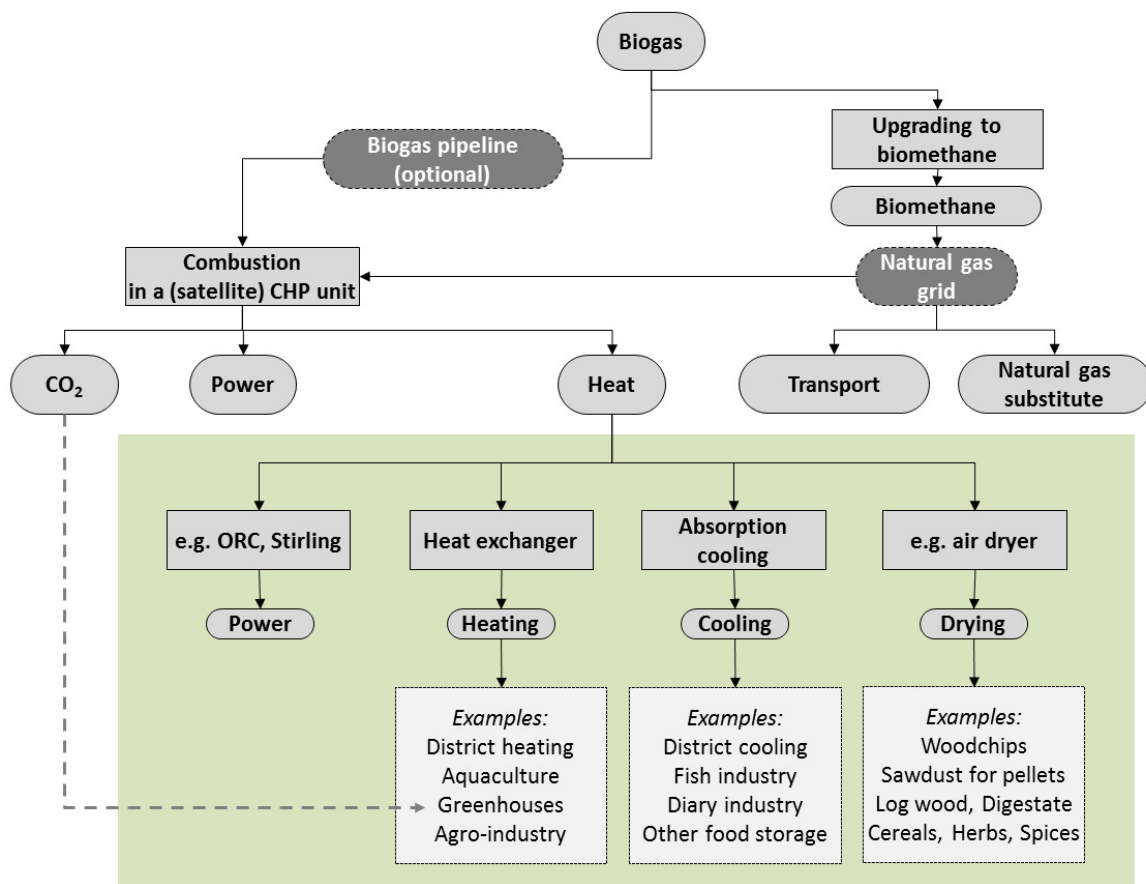

Figure 10: Simplified flowchart for the use of biogas

### 3.1 Heating

The direct use of heat for different applications is among the most efficient solutions for sustainable waste heat use. Thereby, usually fossil fuels can be substituted and GHG emissions considerably reduced. The simplest way of using heat is e.g. for heating buildings and hot water supply for the plant operator, especially if it is an agricultural plant. However, several considerations make other heat use concepts necessary. These considerations include, for instance, the amount of energy. The produced heat of medium sized agricultural biogas plants is often larger than the heat demand of farms. Furthermore, biogas plants may be too far away from buildings, thus creating the need for other heat use options than direct heating. Finally, the quantity and quality of heat demand and supply is influenced by seasonal or daily variations.

For the planning of heating systems, **characteristics of heat demand** have to be assessed as detailed as possible. The following characteristics need to be determined:

- Total heat demand
- Annual heat demand
- Peak heat demand
- Seasonal variation in heat demand

Depending on the size of the heating system, different approaches can be used to determine the characteristics of heat consumers.

- Checking the past invoices of the consumers for heating
- Measurements
- Calculations

Details on the planning process of heating systems are described in chapter 3.1.1, since most biogas plants with a concept for direct heat use include differently sized district heating systems.

#### 3.1.1 District heating

The direct use of heat in district heating (DH) systems is the simplest way of valorising waste heat. The scale of the district heating system can vary from very **small-scale systems** in which only a few households are connected (micro-heating grids) (Figure 12) to **large-scale systems** in which entire cities are connected. Heat from biogas plants can be used to supply both small and large scale systems.

Larger district heating systems are defined as systems for distributing heat generated at a centralized location, such as at a biogas plant, for residential and commercial heating requirements such as space heating and domestic hot water. In larger systems it is also possible to connect several heat generators in the same system. The heat is distributed to the consumers through a network of pipes and directly or indirectly connected through heat exchangers (Figure 11, Figure 15). District heating systems consist of feed and return lines which create a closed heating cycle. They transport hot water or steam to the consumers and cold water back to the heat generators. Due to lower temperatures of heat produced in biogas plants, usually only hot water and no steam is used. The pipes should be very well insulated and installed underground. However, there are also systems with over-ground pipes. The diameters of the pipes are influenced by the size of the system and the volumes of transported water. Additional equipment may include heat exchangers and connection equipment, heat storage systems, and calorimeters.

Depending on the system, the final consumer usually receives the heat through a heat exchanger (Figure 11). However, there exist also systems in which the heating cycle is directly connected to the heating cycle of the consumer. This reduces heat losses of about

5% per heat exchanger, but needs a more sophisticated system and more maintenance efforts since failures could affect the whole system.

Although modern district heating systems are very efficient, **heat losses** are inevitable. Losses should be kept as low as possible, but calculations must always consider a trade-off between the losses and costs for avoiding losses. The following parameters influence the heat losses in a district heating system:

- Length of the piping system
- Insulation of pipes (Figure 13)
- Type of soil
- Thickness of soil cover above the pipes (Figure 12, Figure 14)
- Volume, flow and temperature of the circuit water
- Foreseen temperature difference at the final heat exchanger
- Number of heat exchangers which are connected in series

There are different ways to **express the losses** in a district heating system (Wiese 2007):

- Difference of temperature at the beginning and end of the system
- Relative numbers or percentages of heat losses
- Absolute numbers of heat losses in kW

Usually, **heat pipe** manufacturers include percentages of heat loss for their products. However, for planning district heating networks, it is recommended to use absolute numbers, since this can also reflect the heat losses at different heat loads.

The Ecoheat4cities project ([www.ecoheat4cities.eu](http://www.ecoheat4cities.eu)) has developed a voluntary label for measuring and communicating the performance of district heating systems, including energy renewability, resource efficiency (primary energy factor) and CO<sub>2</sub> efficiency/emissions. It will thus enable actors from all over Europe to see and show how district heating and district cooling can contribute to reaching relevant energy targets and facilitate assessment of DHC as a competitive and viable option in Europe's heating and cooling market.

**Typical consumers** of waste heat from biogas plants are industrial and commercial entities, public entities, and private consumers. Consumers with a usually high and continuous heat demand throughout the year include e.g. large meat producers, aquacultures, laundries, recreation centres, hospitals, swimming pools, and SPAs. Less stable is usually the demand of hotels, canteens, food storages, schools and private residential housing.

The installation of a district heating system for waste heat from biogas plants is associated with considerable **installation costs**. The larger the distances between the biogas plant and the heat consumer, the higher are the costs. In most projects, the distances are kept **smaller than 4 km**. Due to the high installation costs and the large efforts needed for the set-up of a district heating system, **long-term contracts** between the supplier and consumer should be made. Three different concepts can be applied to district heating systems of biogas plants, namely supply of basic heat, full heat supply, and sale to heat service companies.



**Figure 11: Connection equipment (including a heat exchanger) of an end consumer connected to a district heating system in Achenal, Germany (Source: Rutz)**



**Figure 12: Installation of a heat pipe to the buildings of a farm (Source: Thermaflex Isolierprodukte GmbH)**

### **Basic heat supply**

In this concept, the biogas plant operator supplies only the available fraction of the heat from the biogas plant to the heat consumer. The operator does not guarantee the full heat supply. Therefore it is necessary that the heat consumer is also equipped with additional boilers that can be switched-on in case that insufficient heat is supplied by the biogas plant operator. This mainly occurs in times of peak demand or no operation of the biogas plant (e.g. system failure, maintenance). In the basic heat supply system, the risk of the biogas plant operator is reduced to a minimum. However, the biogas plant operator usually does not receive reasonable prices for this heat. Heat consumers generally benefit from very low heat prices, but have to pay for the installation and maintenance of additional boilers.

### **Full heat supply**

In this concept, the whole heat demand is supplied by the biogas plant operator. This includes also the supply of peak demand e.g. in cold winters, as well as the supply in case of system maintenance or failure. In many contracts in Germany, the heat supply for temperatures of down to  $-15^{\circ}\text{C}$  is guaranteed. In this system the biogas plant operator has higher investment costs, since peak or emergency heaters have to be installed. To ensure this, connection to the natural gas grid is beneficial, as natural gas could be burned also in biogas CHP units and burners. In this concept, the risk is higher for the plant operator since he has to guarantee continuous heat supply as it is agreed in signed heat contracts. Since the consumer has fully outsourced the heat supply to the biogas plant operator, higher heat prices can be charged.

### **Sale to local district heating or heat service companies**

Finally, it is possible that the biogas plant operator sells the whole heat to the local DH company or to a dedicated heat service company, also called energy service company (ESCO). The DH company or the ESCo usually buy all heat from the plant operator and guarantees full heat supply to the heat consumer. Therefore, the DH company or the ESCo have to operate peak and emergency boilers. These can run on traditional fuels such as e.g. on natural gas or fossil oil or on biofuels such as biogas from other plant operators, woodchips, biodiesel, or plant oil.



**Figure 13: Insulated pipes for district heating in Germany (Source: Rutz)**



**Figure 14: Construction of a district heating system in Germany (Source: Rutz)**



Figure 15: Spiral heat exchanger in Denmark (Source: Rutz)

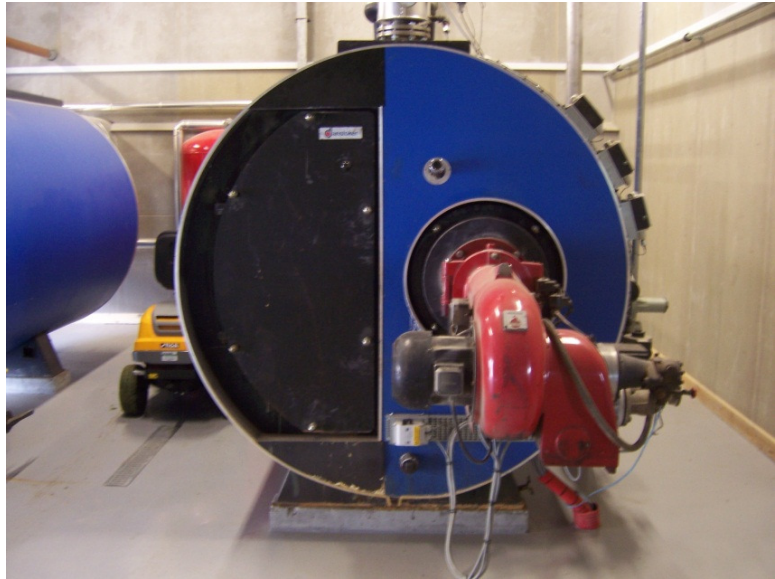

Figure 16: Biogas boiler of 1,500 kW capacity in Denmark (Source: Rutz)

### ***Planning of a district heating system***

For the planning of a district heating network, it is important to consider that usually several **stakeholders** are involved. These may include biogas plant operators, heat consumers, land owners of the transmission route, municipal authority, heat service companies, DH companies, planners, implementing companies and residents. Their participation should already be foreseen at the early planning process. Especially large-scale DH concepts are complex.

In order to realize district heating concepts for waste heat from biogas plants, the project has to be technically and economically feasible. This can be assessed by the investigation of **consumption patterns and data** of existing heat consumers. Thereby, seasonal and daily consumption patterns and peak loads have to be assessed (Schröder 2007). Furthermore it is important to consider future developments, such as planned refurbishments of buildings.

The simplest way of estimating the consumption can be done by **checking the past invoices** of the consumers for heating. It is recommended to check the invoices of several past years. This method is suitable especially if only few consumers will be connected and if the heat demand is far below the heat capacity of the biogas plant.

Another method for the assessment of the heat demand is by **measurements**. These can include hourly, daily or monthly measurements. In existing larger facilities, the heating systems are sometimes already monitored so that these data can be also used. Detailed measurements are needed if full heat demand should be covered or if the total heat demand is close to the available heat supply of the biogas plant.

Using measured data, load curves and load duration curves can be drawn. A heat **load curve** is a graph that shows the actual heat consumption over the course of time, usually one year (8,760 hours). It provides information on the total heat demand, peak loads, and time-related characteristics.

A heat **load duration curve** is similar to a load curve, but the demand data are ordered in descending order of magnitude, rather than chronologically. Figure 17 shows an example of a heat load duration curve for a medium heating system. Furthermore it shows how much heat could be provided as basic load from a biogas plant with 600 kW<sub>th</sub> capacity and about 7,200 operational hours. Thereby, the heat supply of the peak load would have to be

provided by another system. If full heat supply should be covered by the biogas plant, the capacity would have to be about 1,800 kW<sub>th</sub> in this example.

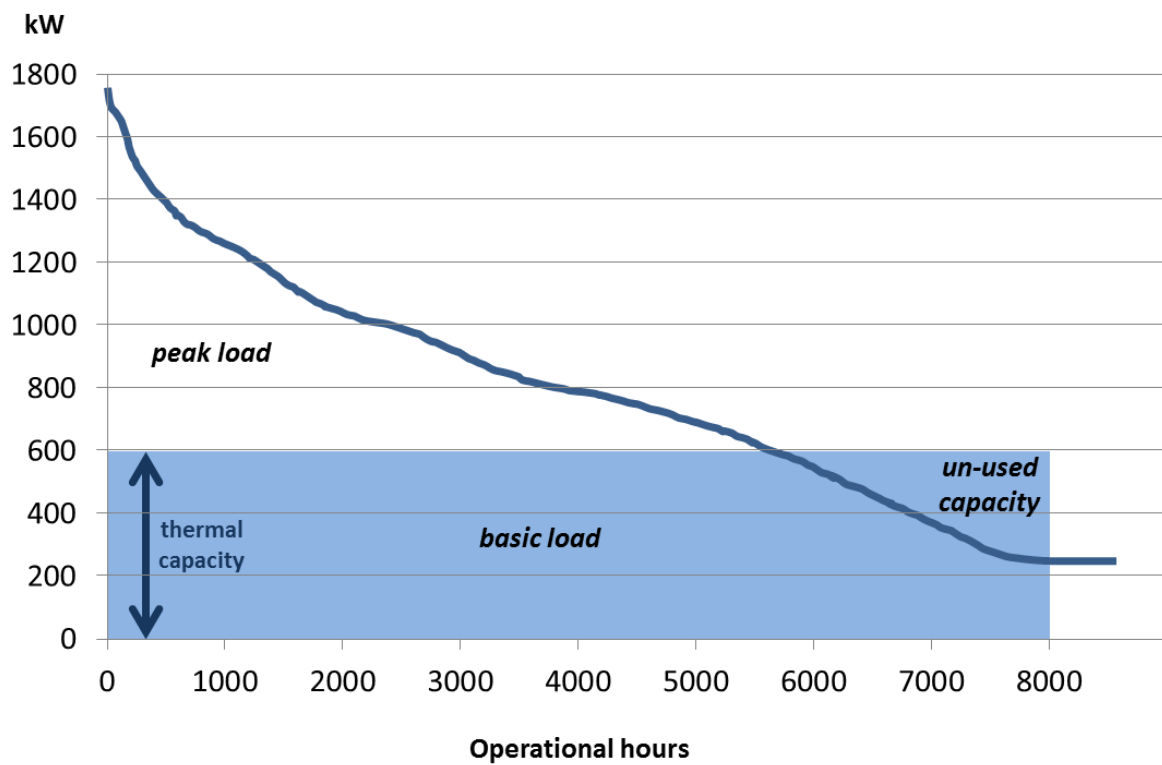

Figure 17: Example of a load duration curve of a heating system including the capacity of a 600 kW CHP unit

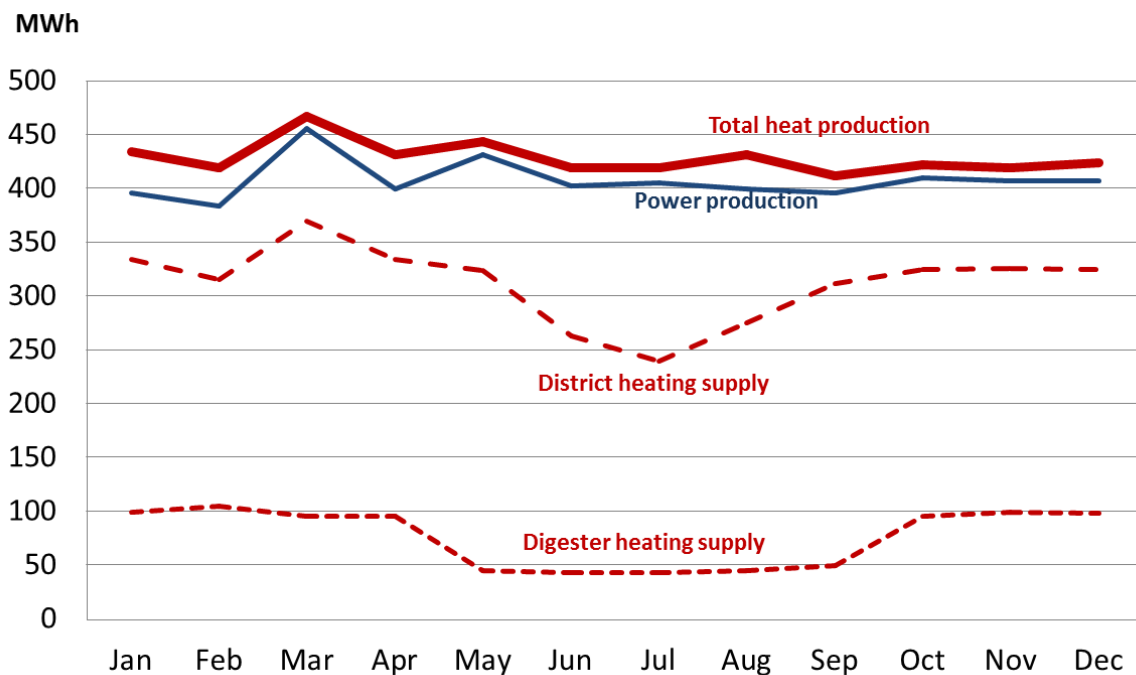

Figure 18: Example of heat supply curves during one year for a 600 kW<sub>th</sub> biogas plant in central Europe

Finally, **calculations** for the heat demand can be made. For the heat demand of buildings, calculations typically include data on the heated living area, status of insulation, number of connected persons using hot water, as well as local climatic parameters.

In addition to the consumption patterns and data, also the **heat supply of the CHP unit** has to be carefully planned. Therefore, the technical data of the CHP manufacturer are important, especially on the total heat capacity. However, reality shows that these data are usually about 3% lower than declared (Gaderer et al. 2007). Furthermore, the heat demand for the digester heating, which varies during different seasons, has to be considered. Figure 18 shows an example of a **heat supply curve** of a biogas CHP unit. In this example, there exists a high heat supply in winter and surplus production of heat in summer.

The heat production as well as the heat demand is highly influenced by **climatic framework conditions**. Thereby, especially the **coldest temperatures of the location** have to be considered, since they influence the amount and duration of the peak load, as well as the maximum capacity of the installed heating system. Climate data are often provided by public meteorological institutions. The climate data are used to calculate, together with data related to the connected buildings (building type and shape, level of insulation, size of window surfaces, and purpose of the building), the exact heat demand and seasonal specifications of a district heating system.

Depending on the system requirements, two different **heat storage systems** may be included in a district heating system. **Buffer tanks** are used for equalizing daily and short-term variations of heat demand. According to an example of Gaderer et al. (2007) in Germany, the use of a buffer tank allows supplying about 20 single-family houses with a 150 kW<sub>el</sub> biogas plant and 57 single-family houses with a 500 kW<sub>el</sub> biogas plant. The other storage systems are **seasonal storage systems** which allow storing waste heat produced in summer for consumption in winter. In this case, Gaderer et al. (2007) showed that about 48 single-family houses with a 150 kW<sub>el</sub> biogas plant and 135 single-family houses with a 500 kW<sub>el</sub> biogas plant can be supplied. Seasonal storage systems are usually borehole heat storages that store the thermal energy in the soil. In these systems the heat is exchanged through U-tubes or through an open pipe system.

### 3.1.2 Stables

Pig and poultry farms produce the whole year meat, also in winter. In order to guarantee continuous production and to increase production, stables are often heated, especially in winter. Linking biogas plants to pig and poultry farms allow the use of manure and litter as feedstock material for the biogas plant and the use of waste heat to acclimatize the stables. These synergies can be used in large-scale animal farming systems. However, also smaller and organic farming units can benefit since generally more (heated) space per animal is needed.

#### **Pig farming**

Pigs are typically raised under different conditions according to their age. Precise heating can significantly contribute to improve the conditions and thus the productivity of the farming system. Pigs require warm and dry stables that protect them from cold winter. The following temperature levels, according to the pig ages, are suitable for pig raising:

- 1<sup>st</sup> week: 32 °C
- 2<sup>nd</sup>- 4<sup>th</sup> week: 28 °C
- 4<sup>th</sup>- 8<sup>th</sup> week: 22-27 °C
- Fattening: 20 °C

Especially young pigs (piglets) need higher temperatures. Different heating systems are available, such as zone heaters or heating mattes. The heat demand per pig is about 16 kWh per month under south German climatic conditions (Schulz et al. 2007).



### **Poultry farming**

Poultry farming is the raising of domesticated birds such as chickens, turkeys, ducks, and geese, for the purpose of farming meat or eggs for food.

Chicken are the most numerous bred poultry. There exist many different systems for breeding, whereas raising in indoor systems is one of the most applied practices. Chicken for meat production, so called broilers, are raised on the floor of large stables. These stables are equipped with feeding systems, ventilation systems and heaters. Typical temperatures of stables for broiler breeding, according to the different ages, of the chicken is summarised in Table 3. A differentiation is made between central heating systems which heat the whole stable and radiant heater which heat only parts of the stable (areas below the heaters) and which are usually operated with electricity.

**Table 3: Optimum temperatures of stables for chicken breeding (Berk 2008)**

<b>Age (days)</b>	<b>Central heating system for the whole stable [°C]</b>	<b>Radiant heater [°C]</b>
1-2	36-34	32-31
3-4	32-31	30
5-7	30-29	29-28
8-14	29-27	28-26
15-21	26-25	25
22-28	24-23	24
29-35	22-20	22-20
36-42	21-19	21-19
>43	20-18	20-18

### **3.1.3 Greenhouses**

Greenhouses (Figure 19) often need much energy for the creation of best growing conditions for the cultivations. Heating costs are usually among the highest operational costs of greenhouses. Temperatures of 20-25°C are often needed, even in cold seasons. Thus, the use of waste heat from biogas plants can constitute a good and cheap heat source. Precondition for this is that the greenhouse is located in the vicinity of the biogas plant.

The most suitable heating system in greenhouses is water heating circuits (Figure 20), as it can be accurately adjusted and as air circulation can be reduced, whereas air heaters have several disadvantages.

An important factor for the determination whether a greenhouse is a suitable heat consumer for waste heat, is the heat demand. Gabloffsky (2007) mentions that the annual fuel demand for greenhouse heating of 20°C in Germany can still reach about 600 kWh/m<sup>2</sup>. Better insulation of greenhouses is developed, but it is still limited due to the fact that also enough light has to penetrate the transparent cover. Equation 6 can be used for the determination of the heat demand (BDEW 2009):

$$\dot{Q} = A \times u' \times (t_i - t_a)$$

**Equation 6**

$\dot{Q}$	Heat demand [W]
A	Surface of the transparent cover [m <sup>2</sup> ] (also floor area in [m <sup>2</sup> ] x 1.4)
u'	Heat demand coefficient [W/m <sup>2</sup> K]
t <sub>i</sub>	Inner greenhouse temperature [°C]
t <sub>a</sub>	Minimum ambient temperature of the location [°C]

The heat demand coefficient u' is a value for the heat demand of different greenhouse types and ranges from 4.6 for double-glazed greenhouses with a mixed heating system to 10 for simple greenhouses with foils and elevated heat pipes above ground.

It has to be considered that the highest heat demand for greenhouses occurs in the cold season, namely in winter as well as in late autumn and early spring. Also the heat available from the biogas plant is lower in the cold season, since more energy is needed to heat the digesters. Heat storage facilities can equalize the variations, but generally are very cost intensive. For the exact planning of the heat demand of a greenhouse, detailed calculations are necessary.

Finally, also the use of CO<sub>2</sub> from the exhaust gas stream of the CHP unit should be considered, since CO<sub>2</sub> improves the plant growth.



**Figure 19: Acclimatised glasshouses in Germany (Source: Rutz)**

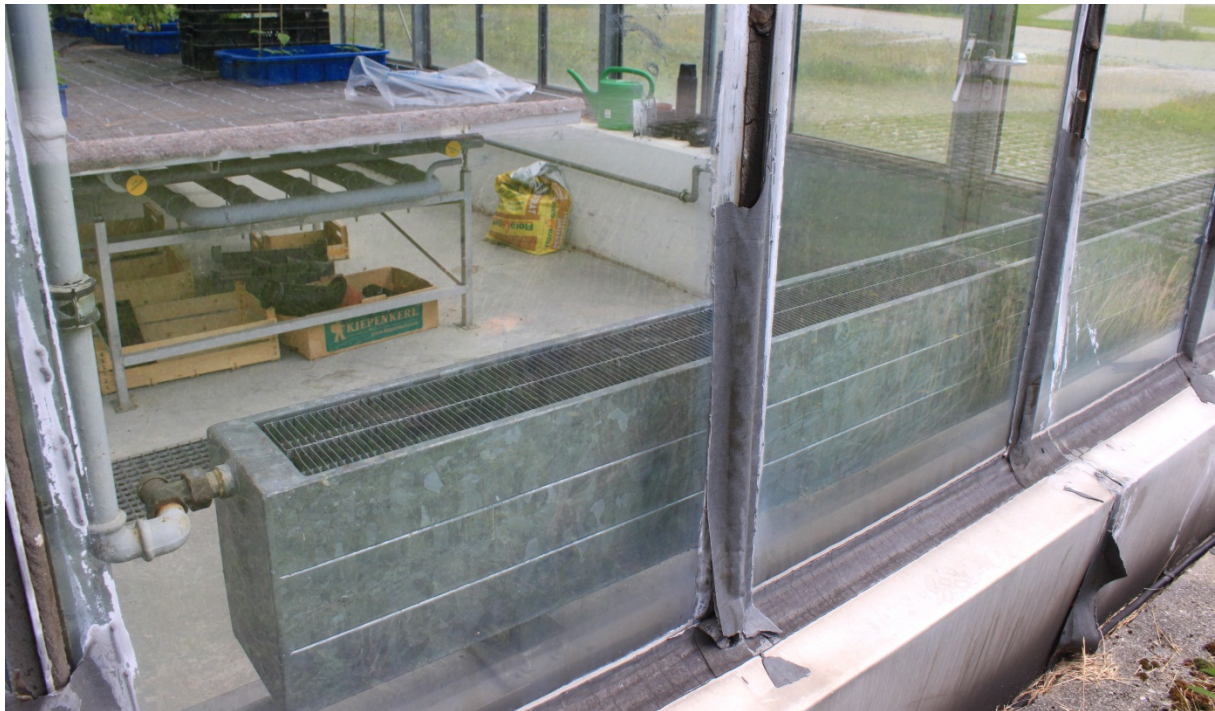

**Figure 20: Radiator of a glasshouse heating system in Germany (Source: Rutz)**

### 3.1.4 Aquaculture

There are many opportunities for integrated aquaculture systems. For instance in an Integrated Fish Farming & Irrigation system (IFFI) a fish farm facility is set-up between the water source and the irrigated field providing nutrients to the field. In the example of the Aquaponic concept, the aim is to develop a sustainable eco-technology to integrate and combine aquaculture and horticulture with minimized emissions and optimizing reusable water flows. The acronym Aquaponic consists of the words aquaculture (fish) and hydroponic (vegetables). There exist many other similar concepts.

In general win-win situations can be created if biogas plants and aquacultures are linked. In some systems, the digestate is used as a fertilizer for the aquaculture. In other systems, the waste from aquaculture is used as feedstock material for biogas plants.

In the last years, a new concept was developed which gained increasing interest in Europe, namely the use of the waste heat of biogas plants for heating aquacultures. Fish and shrimps from the sea or other water bodies are generally becoming scarcer. Thus, they are increasingly cultivated artificially and often with high environmental impacts. Heated aquacultures are still rare in Europe due to the high energy costs. The use of the waste heat from biogas plants offers new opportunities for farmers to produce additional high-quality products. Aquaculture can be an interesting new income source which also allows the cultivation of tropical species under European climates.

Several projects in central Europe have been recently set-up and are promising. However, such projects are associated with high risks and a precondition is a high interest of the operator in aquaculture. The following aspects are important for planning aquaculture projects:

- Connection to (several) water and wastewater lines
- Knowledge of the operator on aquaculture
- Knowledge of the operator on fish slaughtering and marketing
- Availability of a (local) market for the products

- Price and quantity of the products
- Legal framework conditions
- Investment costs
- Availability and suitability of technologies

Heated aquacultures can be land based hatcheries, but increasingly **closed system aquacultures** or also called **close-loop circuit fish farms** or recirculating aquaculture systems are implemented. Systems exist for both freshwater and salt water fish and shrimp species, as well as for species of temperate and tropical climates. Closed system aquacultures in Europe are usually set-up in halls, especially if tropical species are kept that require considerable heating efforts. The system usually consists of several ponds which can be made of concrete or synthetic material. There exist different approaches for the circulation of the water, which can undergo a cleaning process either in a centralized facility or for each pond separately.

For the cultivation of the species **ideal growing conditions** have to be created. These conditions are influenced by the following parameters: feeding, water quality, general hygienic conditions, ventilation, water temperature, and number of fish per volume. One of the most crucial parameters is the cleanliness and hygienic conditions in order to avoid diseases and pathogens and thus to avoid the need for medicine applications. Due to microorganic filter systems, no antibiotic medicine can be applied as these would negatively influence or destroy the microorganisms of these filter systems. Several parameters can be monitored and automatically controlled to guarantee a continuous process.

Another crucial parameter is the **energy consumption**, whereas about one third of energy supplied is needed as electricity and about two thirds as heat (Schulz et al. 2007). Heat is needed to heat the water and to acclimatize (heat and cool) the halls. Temperatures for heating the ponds vary depending on the shrimp or fish species. Ideal water temperatures range between 20°C and 32°C. For instance, African sharptooth catfish (*Clarias gariepinus*) is grown in a project in Germany (Landgenossenschaft Pröttlin) at 27°C. In another project in Germany ([www.garnelenhof.de](http://www.garnelenhof.de)), white tiger shrimps (*Peneaus vanamei*) are grown at optimum temperatures of 30°C. Table 4 indicates ideal water temperatures for different species.

Examples of technology manufacturers that are involved in combined biogas-aquaculture projects are PAL Anlagenbau GmbH ([www.pal-anlagenbau.de](http://www.pal-anlagenbau.de)), F & M Anlagenbau GbR ([www.f-m-aqua.de](http://www.f-m-aqua.de)), and International Fish Farming Technology (<http://p113585.typo3server.info>).

The needed space for closed system aquacultures depends on the kept species, but ranges between 6 and 10 m<sup>2</sup> per ton of annual production (Schulz et al. 2007). Often existing old agricultural halls could be used for the installation of the aquaculture. For a typical plant of 100 t/yr one full-time employee is needed (ibid.). The employee should have good knowledge on aquaculture and on the process. The typical investment cost for a closed system aquaculture of 100 t/yr capacity is about one million Euros, but depends very much on the size, species, process, etc. (ibid.).

Apart from the heat demand for water heating and acclimatization of the halls, heat is also needed for subsequent processing steps, such as for the slaughtering process. Hot water is needed for cleaning the equipment and to guarantee hygienic conditions. Heat can furthermore be converted to cool the fish.

**Table 4: Needed water temperatures for different fish and shrimp species**

Species name	Scientific name	Temperature [°C]	Type
European eel	<i>Anguilla anguilla</i>	23-25	Freshwater fish
African sharptooth catfish	<i>Clarias gariepinus</i>	27	Freshwater fish
Giant fresh water shrimp	<i>Macrobrachium rosenbergii</i>	26-32	Freshwater shrimp
Black tiger shrimp	<i>Penaeus monodon</i>	24-34	Saltwater shrimp
White tiger shrimp	<i>Peneaus vanamei</i>	30	Saltwater shrimp
Zander	<i>Sander lucioperca</i>	22-25	Freshwater fish
Turbot	<i>Scophthalmus maximus</i>	16-20	Saltwater fish
Wels catfish	<i>Silurus glanis</i>	24	Freshwater fish
Tilapia	<i>Tilapia sp.</i>	24-26	Freshwater fish

### 3.1.5 Heat transport in containers

In several cases it may not be possible to install district heating systems either as the distances are too far or as it is not possible due to legal or other framework conditions. In these cases, the heat transport via storage systems in containers may be considered. However it must be noted that this technology is not yet widely applied. Only few manufacturers are currently offering heat storage systems in containers.

The idea is to store the heat of the biogas plant in mobile containers, usually in standardised non-insulated 20 feet containers (6.10 m x 2.44 m). The containers do not have to be insulated as the energy is chemically stored and not by increased temperature as in other storage systems. Once the container is loaded, it can be transported by trucks to the heat consumer. Transport distances could be between 1 and 30 km for a 500 kW<sub>el</sub> biogas plant (Gaderer 2007). According to Kralemann (2007) the distance should not be longer than 20 km, if the maximum operational workload is 4,000 hours.

The challenge is the storage technology inside the container. There exist two main technologies for the heat storage:

- Latent heat storage systems
- Thermodynamic storage systems

In **latent heat storage systems** the heat is stored by using the melting heat of a substance that is called phase change material (PCM). During the loading phase, the PCM changes its phase from solid to liquid whereas the temperature is not increased (isothermal phase change). If the process is reversed, the heat can be used again. The available and desired temperature levels influence the selection of the PCM which is characterised by its melting temperature.

In latent heating storage systems for biogas plants, PCM can be, for instance, dissolved **sodium acetate** (trihydrate) which is a non-hazardous salt. Dissolved sodium acetate has a

melting point of 58°C. The heating or loading circle is separated from the PCM, so thermal energy has to be transferred within the storage material. For the loading process a temperature difference of at least 10°C should be available, thus 68°C are needed at the heat source for heat storage in dissolved sodium acetate systems. The low melting temperature allows only the use of this system for applications that need low temperatures of about 48°C. Thus, applications for this system are limited.

A 20 feet and about 26 t container has a heat storage capacity of about 2.5 MWh which is equivalent to about 250 l heating oil (Schulz et al. 2007). The load capacity is about 250 kW at temperatures of 70/90°C and the loading time about 10 hours (ibid.). The consumption capacity is about 125 kW at temperatures of 48/38°C and the consumption time about 20 hours (ibid.).

Another suitable PCM is dissolved **barium hydroxide** (octahydrat) with a melting point of 78°C. Due to its hazardous characteristics, special safety requirements are needed.

Cost effective storage systems demand high internal heat fluxes, which depend mainly on the heat conductivity of the storage material. Non-metallic storage materials usually show low heat conductivities, especially the solid phase behaves like a thermal isolator. The increase of the effective heat conductivity in the storage material is essential for the development of cost effective storage systems (DLR 2012)

Technology providers currently include the companies LaTherm ([www.latherm.de](http://www.latherm.de)) (Figure 23) or Transheat ([www.transheat.de](http://www.transheat.de)). Transheat offers a container (Figure 22, Figure 21) in which the heat is transferred by a heat exchanger to a thermal oil. This oil is pumped into the tank where it is mixed with sodium acetate, thereby transferring the heat and storing the heat by melting the salt.

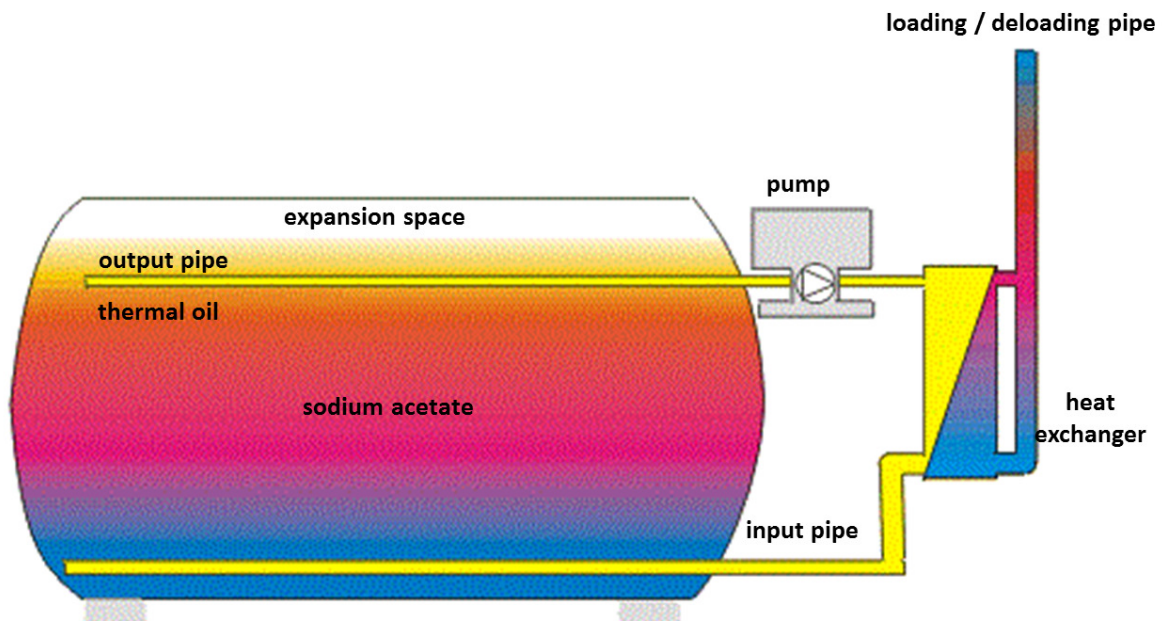

Figure 21: Scheme of a latent heat storage system (adapted from TransHeat GmbH)



Figure 22: Railway wagon with a latent heat storage system (Source: TransHeat GmbH)



Figure 23: Trailer with a container and a latent heat storage system (Source: LaTherm GmbH)

In **thermodynamic storage systems** (sorptive thermal storage) Zeolites are used. Zeolites are microporous, aluminosilicate minerals commonly used as commercial adsorbents. Due to its porous structure, Zeolites have a very large surface area. A single gram of Zeolite pellets has a surface area of up to 1,000 m<sup>2</sup> (Fraunhofer 2012). When water vapour passes Zeolite material, the vapour is adsorbed and heat released. Therefore these systems are not only suitable for heat storage, but also at the same time for drying purposes. The system is re-loaded by dry and hot air.

According to Fraunhofer (2012), the system can store three to four times the amount of heat that can be stored by water. Thus, it only requires storage containers around a quarter the size of water tanks. Furthermore, the heat can be stored for a long period. Energy losses occur only in the charging and de-charging process of the container, but not during the storage duration itself, as the energy is chemically bound.

Nevertheless, this system is not yet commercially available. Researchers of the Fraunhofer Institute, Germany, are currently developing applications on a demonstration scale with a 750 l storage volume.

Generally it has to be considered that a sophisticated logistic system has to be implemented for a continuous heat supply. Enough storage containers have to be available and loading and de-loading times have to be considered. The minimum number of containers can be calculated by the following formula (Schulz et al. 2007):

$$N = n_L + n_C = \frac{\dot{Q}}{\dot{Q}_L} + \frac{\dot{Q}}{\dot{Q}_C} \tag{Equation 7}$$

- N Minimum total number of containers
- n<sub>L</sub> Minimum number of containers on the loading site
- n<sub>C</sub> Minimum number of containers at the consumer
- Q̇ Total needed thermal capacity [kW]
- Q̇<sub>L</sub> Loading capacity of one container [kW]
- Q̇<sub>C</sub> Consumption capacity of one container [kW]

The loading duration is usually larger than the re-loading duration for heat consumption. Furthermore, it is important to ensure good road access which allows the transportation of 26

t containers, as well enough space at the connecting points. The involvement of an external logistics company may be considered as well.

As it was mentioned already, systems for heat transport in containers are not yet implemented at a large scale. For the set-up of new projects the following factors have to be considered:

- Application is only recommended if no other solutions for direct heat use (installation of heat or gas pipes) can be applied
- Maximum transport distances of 30 km
- General risk due to lack of long-term experience with these systems
- Minimum needed heat capacity of 250 kW
- Minimum heat demand of 125 kW
- Depending on the system, only low temperature levels can be offered (e.g. 48 or 78 °C)
- Suitable road access and enough space for the containers is necessary
- Conflicts with neighbours due to increased traffic shall be avoided
- The number of loading cycles is theoretically unlimited, but no long-term experience exists

### 3.1.6 Heating for other purposes

There are many other opportunities of heat use either directly or indirectly as cooling or drying facility. Examples include:

- **Medicine production:** heating for drying and extraction processes from herbs
- **Laundries:** hot water for washing of textiles
- **Dairy industry:** heating and cooling of milk products
- **Microalgae production:** heating and cooling of reactors and CO<sub>2</sub> fertilization
- **Agro-food industry:** hot water and steam for processing, cleaning and hygienisation
- **Waste management:** hygienisation of waste feedstock

## 3.2 Drying

Besides the direct use of heat for rising temperature levels for different purposes, waste heat from biogas plants can be also used for drying of several materials. The most important ones for biogas plants are drying of digestate, sewage sludge, solid biomass (woodchips, sawdust, log wood), and agricultural products. The drying process of materials is generally influenced by the following characteristics:

- Temperature
- Heat quantity
- Air moisture content
- Material moisture and water content
- Process time
- Ventilation speed
- Type and shape of the material



The applied **temperature** depends on the material that should be dried and the purpose for what the material should be used. Woody products can be dried at higher temperatures, whereas food shall be dried at lower temperatures and seed material (that needs to be able to germinate again) at lowest temperatures.

Besides the temperature, also the **air moisture content** is an important factor that influences the drying process. With increasing temperatures, the maximum vapour content of air can be higher. When the relative humidity is 100%, the air is saturated with water. To estimate and plan drying processes, often h-x diagrams are used (Figure 24). They show the absolute water content in humid air (x), relative humidity (%), temperature (°C), and enthalpy (h). With these diagrams the maximum amount of water, that air can take up from the dried material, can be estimated. In the example (adapted from Kirchmeyr & Anzengruber 2008) of Figure 24, it is roughly shown how much additional water (vapour) can be taken up if the temperature is 20°C and if the relative humidity of input air is 10%. It is about 0.0094 kg water per kg air (0.005 kg/kg minus 0.0144 kg/kg). To receive exact figures, calculation tools must be used.

The diagram shows furthermore that the air moisture level of the input air gets less important and even negligible for the drying process, the higher the temperature levels raise.

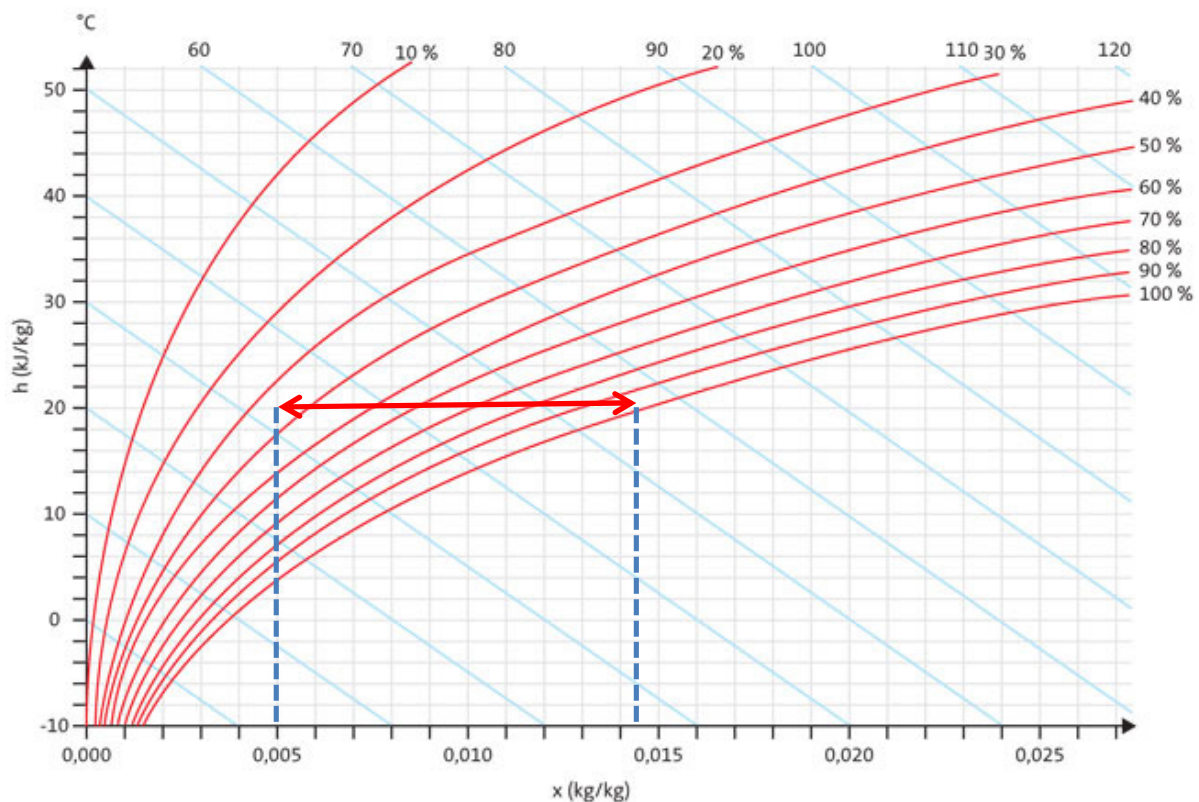

Figure 24: h-x diagram (at 1,013 mbar) of Mollier (Source: adapted from Grundfos 2012)

**Table 5: Water content in air at different temperature levels (Kirchmeyr & Anzengruber 2008)**

Temperature in °C	Maximum water storage in air at 35% relative humidity [g/kg]	Maximum water storage in air at 100% relative humidity [g/kg]	Additional water uptake in air [g/kg]
20	5.0	14.4	9.4
30	9.1	36.1	16.4
40	15.9	45.4	26.9
50	39.6	113.1	73.5

The **water content** and the **moisture** of biomass (wood, herbaceous plants) are two important determinants which characterize the water contained in the material. They can be calculated by Equation 8 to Equation 12.

$$m_w = m_m - m_d \quad \text{Equation 8}$$

$$w = \frac{m_w}{m_m} \times 100 \quad \text{Equation 9}$$

$$u = \frac{m_w}{m_d} \times 100 \quad \text{Equation 10}$$

$$u = \frac{w}{100 - w} \quad \text{Equation 11}$$

$$Hu_w = \frac{[Hu_a \times (100 - w)] - (2.44 \times w)}{100} \quad \text{Equation 12}$$

$m_w$  Mass of water in the material [kg]

$m_m$  Mass of moist material [kg]

$m_d$  Mass of dry material [kg]

$w$  Water content [%]

$u$  Material moisture [%]

$Hu_w$  Energy value [MJ/kg] of material at water content  $w$

$Hu_a$  Energy value [MJ/kg] of dry material in anhydrous state

2.44 Vaporisation energy [MJ/kg] of water at 25°C

The water content  $w$  and the moisture  $u$  are related to each other and can be easily converted (Equation 11). Thus, the water content of 50% is equivalent to the moisture of 100%. The moisture can be above 100%. The typical water content of fresh wood is about 45-60%.

Another important factor in the drying process is the **time** needed to dry the material as well as the **seasonal timing** of the dried material. The seasonal timing of some materials is shown in Table 6. This table also includes maximum drying temperatures.

Table 6: Timing and temperatures of drying for different materials

Material	Drying season	Maximum drying temperatures [°C]
Woodchips and log wood from forestry	Winter	55-150
Woodchips and log wood from landscape maintenance	Whole year	55-150
Woodchips from short rotation plantations	Winter	55-150
Cereals	July – August	30-65
Medical plants and spice plants	June – October	25-50
Digestate and sewage sludge	Whole year	55-95

There exist many different **drying technologies**. Suitable technologies for the relatively low temperatures of waste heat from biogas plants include charge driers, belt driers and feed-and-turn driers (Table 7).

Table 7: Drying technologies and their main characteristics

Drier type	Drying materials	Characteristics
<b>Charge drier</b>	Grain, corn, seed and other bulk materials	Hot air is passing the material in horizontal or vertical bunkers, either in fixed silos, lorries or containers. It is one of the simplest driers as the material is not actively moved. It is also very cheap and suitable for small capacities: for farms of up to 100 ha cultivated cereals area or for heat availability of up to 500 kW <sub>th</sub> .
<b>Belt drier</b>	Bulk goods such as digestate (separated), wood chips, grain, corn, corn silage	Hot air dries the material that is slowly forwarded on a belt. Due to the higher investment costs, this technology is generally suitable for heat availability of more than 500 kW <sub>th</sub> .
<b>Feed-and-turn drier</b>	Oil plants, herbs, grass, pellets, granulates, wood chips, pomace	Hot air is blown through a double bottom (grid bottom) through the product. Turning devices such as paddles mix and convey the product.
<b>Drum driers</b>	Bulk material from agriculture and landscape maintenance	Material passing a horizontal drum. Since high temperatures are needed (1,000°C), this drier is not applicable to biogas plants.

### 3.2.1 Digestate and sewage sludge

Digestate is the remainder of anaerobic digestion plants and sewage sludge of wastewater treatment plants. Depending on their composition and characteristics, they can be used without any further treatment, e.g. as fertilizer. Storage, transport, handling and application of digestate results in significant costs, compared with its fertilizer value; this is due to the large volume and low dry matter content.

Such costs for **digestate** increase significantly in countries with intensive animal production areas, such as Denmark, Germany, Italy and France, where strict national environmental regulations restrict the amount of nutrients to be applied per unit of agricultural land (Al Seadi et al. 2013). These regulations make it necessary to transport and redistribute the nutrients away from intensive used agricultural areas. In order to decrease transport costs, digestate has to be further processed.

The first step in a digestate processing system is the solid–liquid separation, which separates liquid digestate into high dry matter solid material and low dry matter liquid. This separation is often done mechanically such as with screw press separators or decanter centrifuges. The dry phase of the digestate can be further composted or dried.

Drying of digestate can be done with **solar dryers** in glasshouses or with waste heat from biogas plants. The two systems can be also combined (hybrid drying). In a **belt dryer** (Figure 25) the digestate is continuously and evenly transported through an in-feed chamber onto a perforated belt. The belt carries the product through the drying area. In these cells hot air or exhaust gas flows through or over the wet digestate and dries it. The dried material can be used in the horticultural and gardening sectors either directly or in pelletized form. The material can be used also in nurseries or for special cultivation systems, such as for mushroom production. The local situation and markets influence the marketability of compost or dried digestate. Furthermore, quality standards and legislation on fertilizers and compost products need to be considered. Especially for waste treating biogas plants, concentrations of heavy metals may be a barrier for the sale of digestate products. This may influence opportunities if the products are either used on agricultural fields for food production or applied to non-food production areas, such as gardens, parks, etc. These local framework conditions affect the revenues of the plant operator.

Further treatment is often a mandatory requirement for the use of **sewage sludge** as several (such as the German) regulations do not allow dumping sewage sludge without any further treatment on landfill sites. Therefore, either direct application as fertilizer (which is also regulated due to contaminants) or drying with adjacent incineration is needed. Drying methods are generally the same as for digestate drying. Dried sewage sludge can be combusted in incineration plants.

Generally, the heat demand for digestate or sewage sludge drying is continuous with small seasonal variations due to lower ambient temperatures. However, if the systems are large enough, material can be dried according to the heat availability. This method is an efficient way to use large amounts of the waste heat.

The use of heat for drying digestate and adjacent pelletizing is currently under discussion for several biogas concepts. The digestate pellets can be used for power generation in a larger incineration plant. However, this procedure contradicts the idea of creating closed nutrient cycles and of the replacement of artificial by organic fertilizers. Therefore, this approach is not recommended by the authors.



Figure 25: Belt dryer for digestate drying in front of a biogas plant (Source: STELA Laxhuber GmbH)

### 3.2.2 Log wood, woodchips, and pellets

The demand for solid biomass and especially for wood products is steadily increasing due to its increased use for heating purposes. Wood that is just cut contains high amounts of water of 50-65%. This water is chemically and physically bound in the wood.

Depending on the final use, wood has to meet often certain minimum standards regarding its maximum water content. Especially for smaller combustion units, wood has to be considerably dry, due to the following reasons (Rutz et al. 2006; Hiegl et al. 2011):

- The higher the water content, the less energy efficient is the combustion, since part of the energy is “lost” for vaporization. The lower heating value is higher if the wood is dry.
- Storability is better if the water content of wood is below 25%, as the living conditions for microorganisms (fungi and bacteria) are more difficult under dry conditions.
- The growth of microorganisms leads to a loss of material, which reduces the energy content.
- Released spores of fungi (in woodchips) may lead to health risks.
- Further processing of some products requires minimum moisture contents. For instance, sawdust from fresh wood needs drying before it can be pelletized.
- Logistical benefits for long-distance transport, since the weight and the volume are reduced.

The relation of the heating value of wood relative to the water content is shown in Figure 26. The higher the water content, the lower is the heating value.

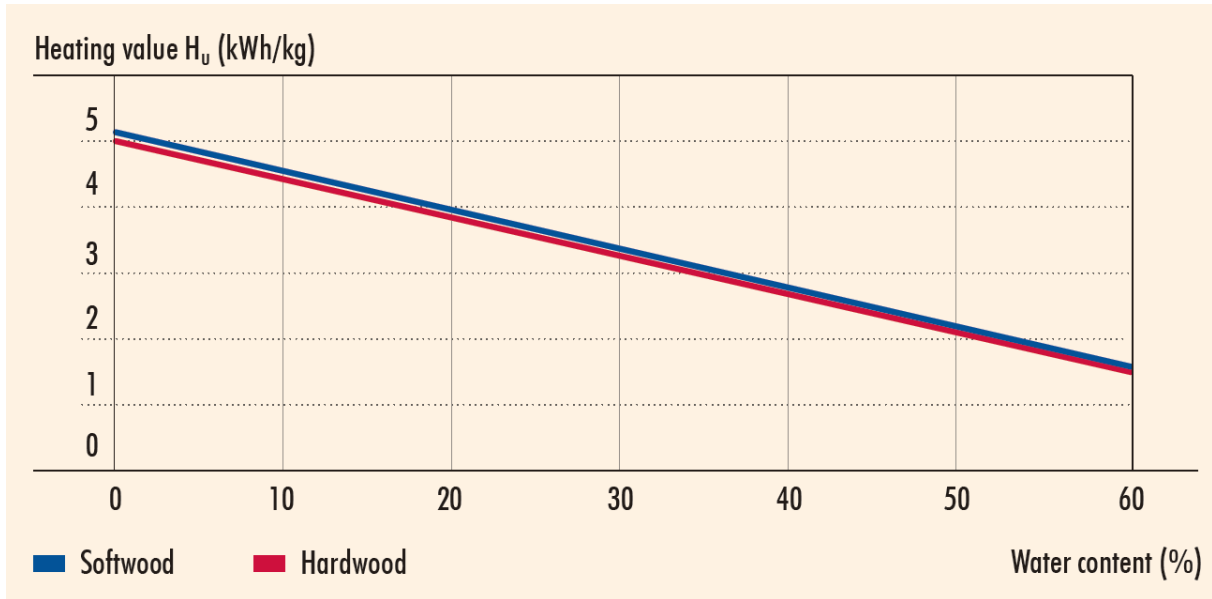

Figure 26: Heating value of wood relative to the water content (Source: FNR 2012)

Different methods can be applied to dry wood. The simplest method of drying is to store the wood outside for 1-3 years, depending on the thickness and type of the wood. However, due to the increased demand of wood and new production practices (short rotation woody crops), time is getting a limiting factor and costs for long-term storages are an important factor. Therefore, artificial drying is getting more important.

**Logwood** can be obtained from forestry, dedicated wood plantations or from landscape maintenance measures. The water content of logwood should be reduced to levels below 20%. European standards classify logwood into 4 moisture categories (M20, M30, M40, M65), whereas the numbers express the maximum limit of water content. Artificial drying requires considerable low costs for drying. Wood from forestry and dedicated plantations is usually harvested in winter when the water content in the wood is naturally reduced, and when the soil is frozen in order to reduce soil damages. Thus, the waste heat demand for drying logwood is generally higher in winter. In winter, however, the waste heat of biogas plants is generally lower. Therefore, as alternative, harvested wood can be just stored and dried when there is surplus heat available, often in summer. Logwood from landscape maintenance is harvested throughout the year. Thus, a continuous drying demand is created for landscape maintenance wood. Wood that is harvested in summer is very moist. Logwood is typically dried in a drying chamber (charge drier) through which the hot air is blown.

**Woodchips** can be obtained from the same production systems as logwood, but require heavy machinery and is thus usually produced only at larger scales than logwood. The water content of woodchips should be reduced to levels below 20%. European standards classify woodchips into 5 moisture categories (M20, M30, M40, M55, M65). Due to the small particle size, woodchips are sensitive to microorganisms if the water content is too high. Increased microorganism activities lead to increased temperatures of the material which has even caused self-ignition in woodchip storage facilities. Woodchips are typically dried in charge driers, that can be containers (Figure 27, Figure 28) or storage facilities through which the hot air is blown. Also feed-and-turn driers can be used.



**Figure 27: Container and air heating pipes for wood chip drying at a biogas plant in Munich, Germany (Source: Rutz)**



**Figure 28: Container for wood chip drying in Munich, Germany (Source: Rutz)**

**Pellets** are obtained from pressing sawdust into small and standardised pellets that are convenient for using in boilers, ranging from household size to industrial size. Due to their high energy density and homogeneity, pellets can be easily traded and used for automatic feeding systems. The sawdust should be dried at water content levels below 10%. European standards classify pellets into 3 water content categories (W10, W20, W30). The waste heat of biogas plants could be used to dry the sawdust, since the heat demand is continuous throughout the year.

### 3.2.3 Agricultural products

In order to increase the storability of many agricultural products (cereals, herbs, spice and medical plants, hay), they must be dried to meet certain requirements regarding their water content. The water content of these products is influenced by the harvest season and weather conditions during harvest, as well as by general climatic conditions and the purpose of the product. In several cases artificial drying after the harvest is necessary, thus creating opportunities for the heat use in biogas plants. The heat demand for drying these products is seasonal and usually applies mainly during summer. In summer, often a heat surplus from biogas plants exists, which could be ideally used for drying processes.

Among the most frequent drying applications in agriculture is the drying of cereals, especially in seasons with extended periods of rain. The maximum moisture content for good cereals storage is 14.5%. Due to limitations in drying facilities, cereals are often stored at 7°C until they are dried. After cereal storage, the moisture is usually increased again up to about 16-17% in order to facilitate milling. In order to maintain the nutrients or germination capacity of the seeds, drying temperatures should not be higher than shown in Table 8. Thereby, the maximum temperatures decrease with the moisture. Drying technologies for cereals usually include charge driers and feed-and-turn driers.

**Table 8: Maximum temperatures (in °C) for heating of cereals (Strehler 1993 in Karalus 2007)**

Moisture [%]	Wheat [°C]	Rye, oat, barley [°C]	Seed material, brewing barley [°C]
16	55	65	49
18	49	59	43
20	43	53	38
22	37	47	34
24	35	40	30

Even more sensitive to temperatures than cereals are medical plants, herbs, and spice plants which are usually dried in a belt drier. These products are usually dried below 9% moisture levels. Examples of these plants are peppermint, camomile, dill, parsley, chives, and savory.

### 3.3 Cooling

Waste heat from biogas plants can be also used to create cooling capacity. There exist two main principles of cooling devices, namely absorption and vapour-compression chillers.

#### 3.3.1 Overview of chillers

**Vapour-compression chillers** are the most widely used devices for air-conditioning as well as for chilling in domestic and commercial refrigerators. Core of this system is the compressor that is operated with electricity.

In contrast to the operation with mainly electric power in vapour-compression chillers, **absorption chillers** principally use a heat source as main energy for the cooling process. Absorption chillers are an alternative to regular compressor chillers where electricity is unreliable, costly, or unavailable, where noise from the compressor is problematic, or where surplus heat is available as it is the case of biogas plants. Generally, absorption chillers are characterized by the following main benefits when compared to vapour compression chillers (Skagestad & Mildenstein n.d.):

- Lower electrical requirements for chiller operation
- Lower sound and vibration levels during operation
- Ability to utilize recovered heat and convert it to cooling energy
- Refrigerant solutions typically do not pose a threat to ozone depletion of the atmosphere.

Both, absorption and compressor chillers use a refrigerant liquid, usually with a very low boiling point (often less than -18°C). In both types, heat is extracted from one system and thus creating the cooling effect, when the refrigerant liquid evaporates. The main difference between the two systems is the way the refrigerant is changed from the gaseous phase back into a liquid so that the cycle can repeat. The compression chiller changes the gas back into a liquid by increasing pressure levels through a (electrically operated) compressor. An absorption chiller changes the gas back into a liquid by absorption of the refrigerant in another liquid and adjacent desorption with heat. The other difference between the two types is the refrigerant used. Compressor chillers typically use hydrochlorofluorocarbons (HCFCs)



or hydrofluorocarbons (HFCs), while absorption chillers typically use ammonia or lithium bromide (LiBr).

Generally, absorption chillers are categorised as direct or indirect-fired, and as single, double or triple-effect. For using waste heat of biogas plants, only indirect-fired chillers are relevant, although theoretically, also direct-fired chillers could be operated with the direct combustion of biogas. Absorption and compressor chillers can be also combined (cascade or hybrid cooling).

The classification into single-effect, double-effect and the triple-effect absorption chillers is based on the number of heating sources (levels). **Single-effect absorption chillers** have only one heating level of the working fluid (weak solution). **Double-effect absorption chillers** have two stages of vapour generation to separate the refrigerant from the absorbent. Therefore, double-effect chillers have two condensers and two generators. The heat transfer occurs at a higher temperature compared to the single-effect cycle. Double-effect chillers are more efficient, but also more expensive (New Buildings Institute 1998). **Triple-effect absorption chillers** are even further advanced in comparison to double-effect chillers. Triple-effect absorption chillers are under development, as the next step in the evolution of absorption technology (New Buildings Institute 1998).

The use of absorption chillers depends on the waste heat temperature, the used refrigerant and transport medium, as well as on the desired cooling temperature. LiBr/H<sub>2</sub>O absorption chillers are able to cool down to 6°C and NH<sub>3</sub>/H<sub>2</sub>O absorption chillers from 0°C down to -60°C.

In order to compare chillers, the **energy efficient ratio** (EER) is used which is similar to the coefficient of performance (COP) of heat pumps. It is the ratio of the cooling capacity ( $\dot{Q}_C$ ) to the heat input capacity ( $\dot{Q}_H$ ). Thereby, the capacity of the pump ( $P_P$ ) is negligible. The EER of actual absorption refrigeration systems is usually less than 1. Typical EERs for commercially available chillers range from 0.65 to 0.8 for single effect units and 0.9 to 1.2 for double effect units (Skagestad & Mildenstein n.d.).

$$EER = \frac{\text{Cooling capacity}}{\text{Input capacity}} = \frac{\dot{Q}_C}{\dot{Q}_H - P_P} \approx \frac{\dot{Q}_C}{\dot{Q}_H} \quad \text{Equation 13}$$

- EER    Energy efficient Ratio
- $\dot{Q}_C$     Cooling capacity [kW]
- $\dot{Q}_H$     Heat input capacity [kW]
- $P_P$     Capacity of the pump [kW]

The general process of a typical **ammonia-water absorption chiller** is shown in Figure 29. In this process, ammonia (NH<sub>3</sub>) serves as the refrigerant and water (H<sub>2</sub>O) as the transport (absorbent) medium. In the **evaporator** the refrigerant pure ammonia in liquid state produces the cooling effect. It absorbs the heat from the substance to be cooled and gets evaporated. From here, the ammonia vapour is pumped to the absorber. In the **absorber** a weak solution of ammonia-water is already present. The water, used as the transport medium in the solution, is unsaturated and it has the capacity to absorb more ammonia gas. As the ammonia from evaporator enters the absorber, it is readily absorbed by water and the strong solution of ammonia-water is formed. During the process of absorption, heat is liberated which can reduce the ammonia absorption capacity of water; hence the absorber is cooled by the cooling water. Due to the absorption of ammonia, a strong solution of ammonia-water is formed in the absorber. This solution is pumped by the **pump** at high pressure to the **generator** in which it is heated by the waste heat from the **biogas plant** while ammonia is

vaporized. Ammonia vapour leaves the generator, but some water particles also get carried away with ammonia refrigerant due to the strong affinity of water for ammonia. Therefore, it is passed through the **separator**, similar to a distillation column. Water goes back through the regenerator and expansion valve to the generator. The weak ammonia/water solution goes back from the generator to the absorber. Pure ammonia vapour enters the condenser at higher pressure where it is cooled by water. It changes its phase into a liquid state and then passes through the expansion valve where its temperature and pressure falls down suddenly. Ammonia finally enters the evaporator again, where it produces the cooling effect. Thereby the cycle is closed.

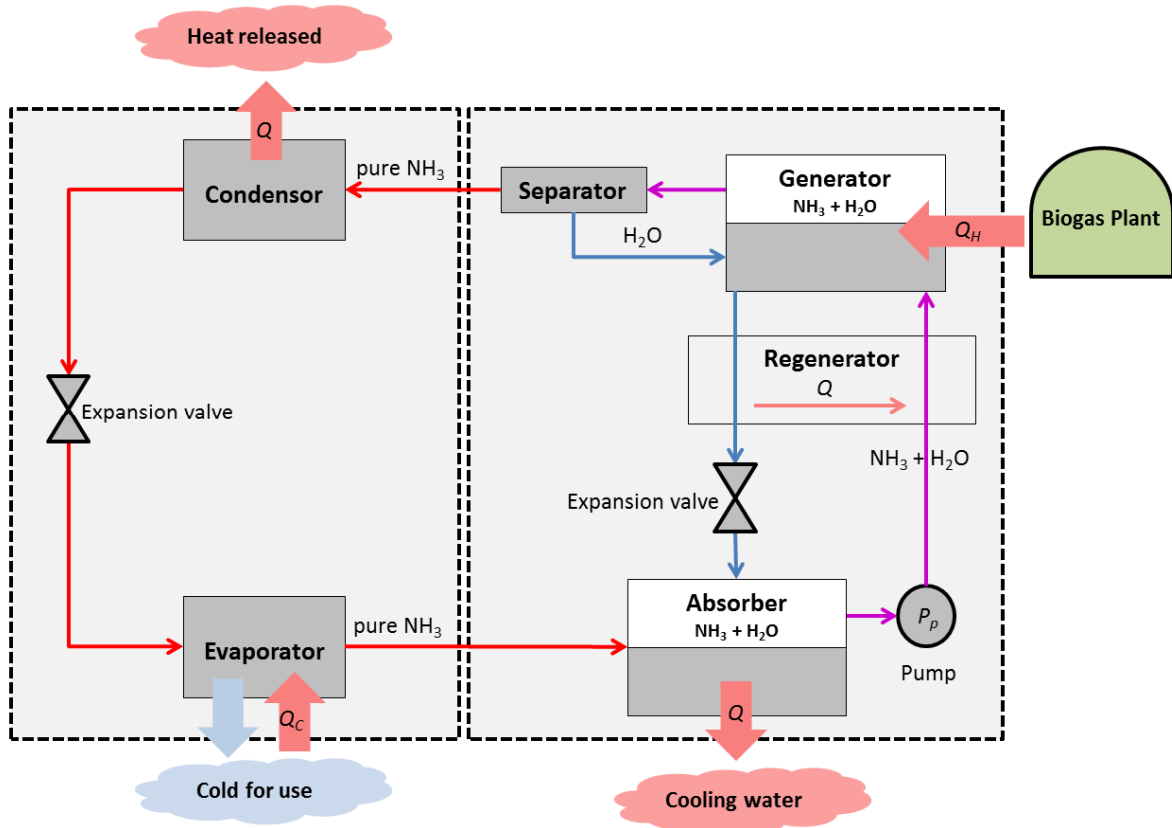

Figure 29: Process of a typical ammonia-water absorption refrigerator

### 3.3.2 District cooling

District cooling is similar to district heating, but distributes chilled water instead of heat. Although the demand for cooling is increasing steadily, due to higher comfort standards and higher temperatures related to climate change, district cooling is not as applied as district heating. Several European cities have introduced district cooling systems, in order to save greenhouse gas emissions (Figure 30).

## ANNUAL CO<sub>2</sub> SAVINGS DUE TO DISTRICT COOLING

- in 2010  
- in 2020

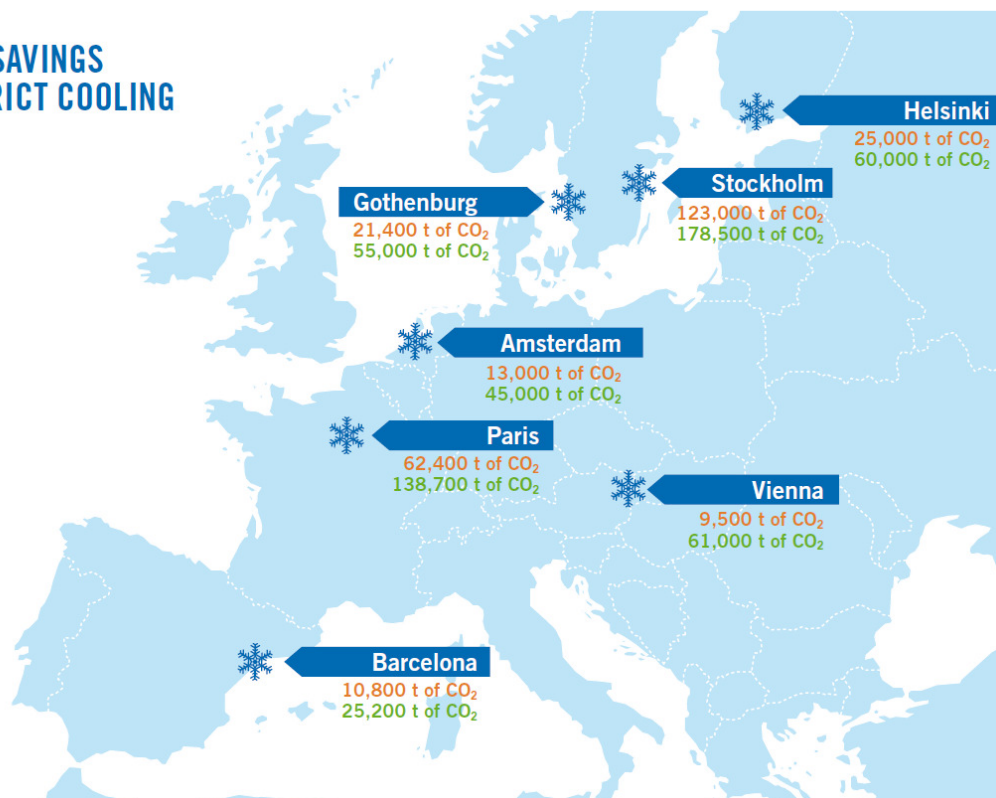

Figure 30: Annual CO<sub>2</sub> savings in selected European cities due to district cooling (Source: Euroheat & Power)

The source of chilling can be from absorption chillers, vapour-compression chillers, and other sources like ambient cooling, or from deep lakes, rivers, aquifers and oceans. Different cooling systems can be also combined. A general advantage of using waste heat from biogas plants for the operation of absorption chillers is the high seasonal availability of heat in summer, combined with the high demand for cooling in summer. Depending on contracts with consumers, cooled water may be provided for both basic and peak demand. Due to the higher investment costs of absorption chillers, additional vapour-compression chillers may be operated during peak demand in order to guarantee peak supply.

The design of the district cooling system is governed by the following key factors:

- The difference of the temperature between supply and return pipes
- Flow velocity
- Network pressure and pressure differential between supply and return pipes.

The successful implementation of district heating and cooling systems depends largely on the ability of the system to obtain high **temperature differentials** ( $\Delta T$ ) between the supply and return water (Skagestad & Mildenstein n.d.). The  $\Delta T$  is typically limited to 8-11 °C. The systems usually adjust the temperature of the chilled water supply based on the outside ambient temperature. District cooling systems can be subdivided into three groups based on supply temperatures (ibid.):

- Conventional chilled water temperatures: 4 °C to 7 °C
- Ice water systems: +1 °C
- Ice slurry systems: -1 °C

Due to the small temperature gradients between the pipe network and the surrounding soil, it is not necessary to insulate the pipes. The underground cooling pipes of the distribution network are usually buried at depths of around 60 cm. In very warm climates and for aboveground pipes, insulation is required.

The maximum allowable **flow velocities** are governed by pressure drop constraints and critical system disturbances caused by transient phenomena. Generally, velocities higher than 2.5 – 3.0 m/s should be avoided unless the system is specially designed and protected to allow for higher flow velocities (ibid.).

### 3.3.3 Applications of cooling

For the set-up of larger district cooling systems, the waste heat from biogas plants is usually too small. However, cooled water from biogas waste heat could be integrated into existing district cooling systems.

Dedicated district cooling systems (micro-district-cooling systems) may be set-up on a much smaller scale for using waste heat from biogas plants, connecting only one or few consumers. Thereby, the advantage is that the largest amount of waste heat from biogas plants is available in summer when there is also a high demand for cooling. However, cooling with waste heat from biogas plants is still a niche application and not widely implemented. Examples for cooling with waste heat from biogas include:

- Acclimatization of public and private **buildings**
- Acclimatization of **food storage** buildings: cereals, vegetables, fruits, meat
- Acclimatization of **stables**: pig farming
- Acclimatization of **server rooms** for data processing
- **Fish industry**: cooling of storage halls and processing of ice
- **Milk industry**: cooling of milk at the farm; cooling for industrial processing of milk and of dairy products
- **Small industry**: process cooling of tools for polymer processing

A special application of cooling is the production of ice. Thereby, the storage of ice can act to temporarily balance heat supply and demand. Furthermore, similar to heat transport in containers, ice can be also easily transported to consumers, thus reducing the requirement of piping in district cooling systems. However this is not very common for waste heat concepts of biogas plants.

## 3.4 Additional electricity production

As it was described already in previous chapters, electricity is a very high quality type of energy since it can be easily converted into other energy forms. Waste heat from biogas plants with temperatures ranging from 80 °C to 550 °C is much less valuable, since it is more difficult to convert it to other energy forms. However, technical solutions exist to convert waste heat to additional electricity in thermodynamic cycles and thereby to gain revenues from high electricity prices.

Generally, a **thermodynamic cycle** consists of a series of thermodynamic processes transferring heat and work, while varying pressure, temperature, and other state variables. Two primary classes of thermodynamic cycles are power cycles and heat pump cycles. Power cycles are cycles which convert some heat input into a mechanical work output, while heat pump cycles transfer heat from low to high temperatures using mechanical work input. In the following chapters some power cycles that could be used for waste heat from biogas plants are described.

### 3.4.1 CRC systems

Heat can be converted into mechanical energy and subsequently into electricity by Rankine cycles (also called Clausius Rankine Cycle, CRC). In a closed loop, usually water is heated, evaporated and passed through a turbine that moves the generator for electricity production. This cycle is used in most traditional and new power generation systems, including in solar thermal, biomass, coal and nuclear power plants.

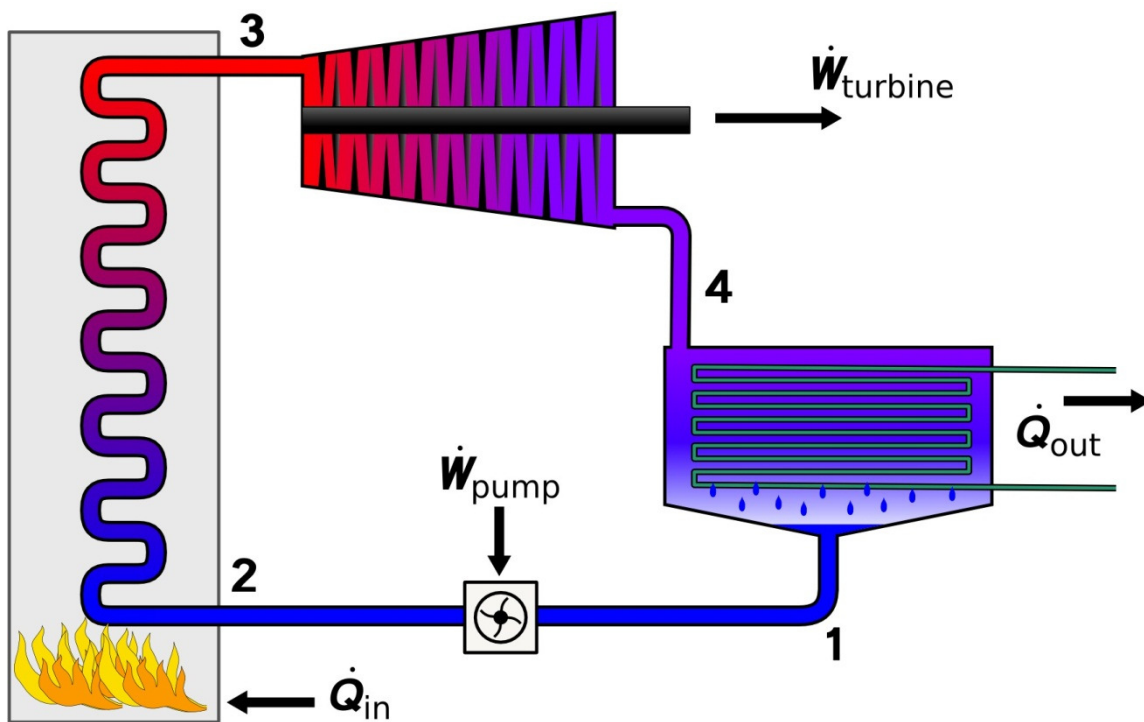

Figure 31: Rankine Cycle layout (Source: English Wikipedia user Andrew.Ainsworth)

There are four stages in the Rankine cycle which are shown by numbers in Figure 31:

- 1-2: The working fluid is pumped from low to higher pressure. As the fluid is a liquid at this stage the pump requires little input energy.
- 2-3: The high pressure liquid enters a boiler where it is heated at constant pressure by the waste heat from the biogas plant to become dry saturated vapour.
- 3-4: The dry saturated vapour expands through a turbine, generating power. This decreases the temperature and pressure of the vapour, and some condensation may occur.
- 4-1: The wet vapour then enters a condenser where it is condensed at a constant temperature to become a saturated liquid.
- The cycle is closed and starts again with the stage of 1-2

The efficiency of the process is calculated with Equation 14.

$$\eta_{therm} = \frac{P_{turbine} - P_{pump}}{\dot{Q}_{in}} \approx \frac{P_{turbine}}{\dot{Q}_{in}} \quad \text{Equation 14}$$

- $\eta_{therm}$  Thermodynamic efficiency of the process  
 $\dot{Q}_{in}$  Heat flow rate to or from the system  
P Mechanical power consumed by or provided to the system

### 3.4.2 ORC systems

As a special form of the Rankine cycle, the Organic Rankine Cycle (ORC) (Figure 32, Figure 33) uses an organic fluid instead of water and steam (Figure 34). This allows using lower-temperature heat sources, such as waste heat from biogas plants with temperatures of 70–90°C. This is due to the lower boiling point of the organic fluids in comparison to the boiling point of water at 100°C. Apart from this difference, the working principle of the ORC is the same as that of the Rankine cycle. The working fluid is pumped to a boiler where it is evaporated, passed through a turbine and finally re-condensed.

The selection of the working fluid is of key importance in low temperature Rankine Cycles. Thereby, the heat transfer efficiency is an important parameter. It influences the thermodynamic characteristics of the fluid and thus the operating conditions. Refrigerants and hydrocarbons are two commonly used fluids. Fluids are characterized furthermore by the following parameters, whereas some fluids are presented in Table 9 and whereas some fluids can be also mixed to increase efficiency:

- isentropic saturation vapour curve
- freezing and boiling point
- maximum tolerant temperature
- latent heat and density
- ozone depletion potential (ODP) and global warming potential (GWP)
- corrosion potential, flammability and toxicity
- availability and cost

It is estimated that from the waste heat of a CHP unit of 1 MW<sub>el</sub>, about 7-10% additional electricity (70-100 kW<sub>el</sub>) can be produced (FNR 2010). The total electrical efficiency of a biogas plant can thereby increase to about 45%. The waste heat from the ORC process can be theoretically further used for heating purposes; however it is often released to the atmosphere.

Figure 35 shows an example of an ORC module for biogas plants. In this example, one unit can generate up to 125 kW of electricity from a heat source of about 980 kW<sub>th</sub>. The minimum heat is 121°C whereas the major part comes from heat recovery from exhaust gases and a smaller part comes from pre-heating of the fluid from the engine cooling cycle.

**Table 9: Characteristics of selected fluids for thermodynamic processes**

Fluid	Critical point [°C]	Critical point [MPa]	Boiling temperature [°C] (at 1atm)	Decomposition temperature [°C]
Water	374.00	22.06	100.00	-
Ammonia (NH <sub>3</sub> )	132.30	11.33	-33.30	477.00
n-Butan C <sub>4</sub> H <sub>10</sub>	152.20	3.80	-0.40	-
n-Pentan C <sub>5</sub> H <sub>12</sub>	196.80	3.37	36.20	-
C <sub>6</sub> H <sub>6</sub>	289.20	4.90	80.00	327.00
C <sub>7</sub> H <sub>8</sub>	5645.00	4.10	110.60	-
R134a (HFC-134a)	101.20	4.06	-25.00	177.00
C <sub>8</sub> H <sub>10</sub>	343.20	3.50	138.00	-
R12	112.00	4.13	-29.80	177.00
HFC-245fa	157.70	3.64	15.40	247.00
HFC-245ca	178.60	3.86	25.20	
R11 (CFC-11)	198.00	4.41	23.20	147.00
HFE-245fa	171.00	3.73	-273.00	-
HFC-236fa	130.80	3.18	-1.00	-
R123	183.90	3.70	28.00	-
CFC-114	145.90	3.26	3.70	-
R113	214.30	3.41	47.40	177.00
n-Perfluoro-Pentan C <sub>5</sub> F <sub>12</sub>	147.60	2.05	29.40	-



Figure 32: ORC system (using R245fa) of a biogas plant in Dublovice, Czech Republic (Source: GE Energy)



Figure 33: ORC system (using R245fa) (container in the front) and biogas engines (container in the back) of a landfill site in Warrington, U.K. (Source: Verdesis Services UK Limited)

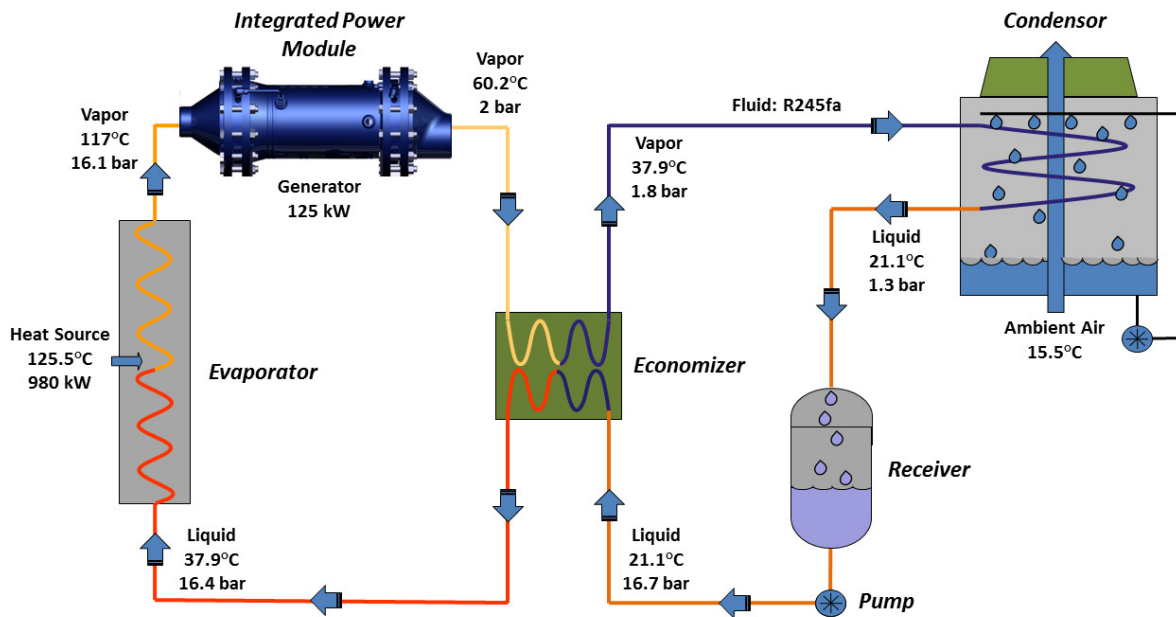

Figure 34: Scheme of the 125 kW "Clean Cycle" ORC Module of GE Energy (Adapted from GE Energy)





Figure 35: “Clean Cycle” ORC Module of GE Energy (Source: GE Energy)

### 3.4.3 Kalina cycle

As an alternative to ORC processes, also a Kalina process can be used to produce electricity from waste heat from biogas plants. However, examples of Kalina cycles for biogas plants are very rare.

In contrast to the ORC process, a fluid mixture of ammonia and water is used. As ammonia and water have different boiling points, the evaporation process happens over a range of temperatures similar to distillation processes. Thereby, more heat can be extracted from the source than with only one working fluid. By appropriate choice of the ratio between the components of the solution, the boiling point of the working solution can be adjusted to suit the heat input temperature. Water and ammonia is the most widely used combination, but other combinations are feasible as well.

The following advantages of the Kalina process in comparison to the ORC process can be mentioned:

- Ammonia and water are cheaper fluids than organic fluids for ORC processes.
- Adaptation to different temperature levels is possible.
- The energy efficiency is higher than for ORC units.

The following disadvantages of the Kalina process in comparison to the ORC process can be mentioned:

- Experience for small Kalina cycle modules for biogas plants is very limited.
- Ammonia has a high corrosion potential leading to higher wear and tear and requiring special equipment.
- Total investment costs are higher than for ORC units.
- Ammonia is poisonous and odorous, thus release to the environment has to be avoided.

- Ammonia is flammable and explosive.

### 3.4.4 Stirling engine

A Stirling engine is a heat engine operating by cyclic compression and expansion of air or another gas at different temperature levels by using an external heat source, such as waste heat from biogas plants. In the Stirling engine heat energy is converted into mechanical work, whereas a generator can be operated to produce additional electricity. The basic principle of the engine is a cycle in which cool gas is compressed, heated, expanded, and finally cooled down before the cycle is repeated. Thereby the system is closed and no gas is added to or released from the engine, therefore it is also classified as an external combustion engine. Heat is transferred through a heat exchanger at the engine that heats the gas in the engine.

There exist different types of Stirling engines, such as the two piston alpha type and the displacement type Stirling engines, known as beta and gamma types. In order to understand the principle of a Stirling engine, Figure 36 shows the 4 phases of an alpha type engine. An alpha Stirling contains two power pistons in separate cylinders, one hot and one cold. The hot cylinder is situated inside the high temperature heat exchanger and the cold cylinder is situated inside the low temperature heat exchanger. This type of engine has a high power-to-volume ratio but has technical problems due to the usually high temperature of the hot piston and the durability of its seals. In practice, this piston usually carries a large insulating head to move the seals away from the hot zone at the expense of some additional dead space. (Wikipedia)

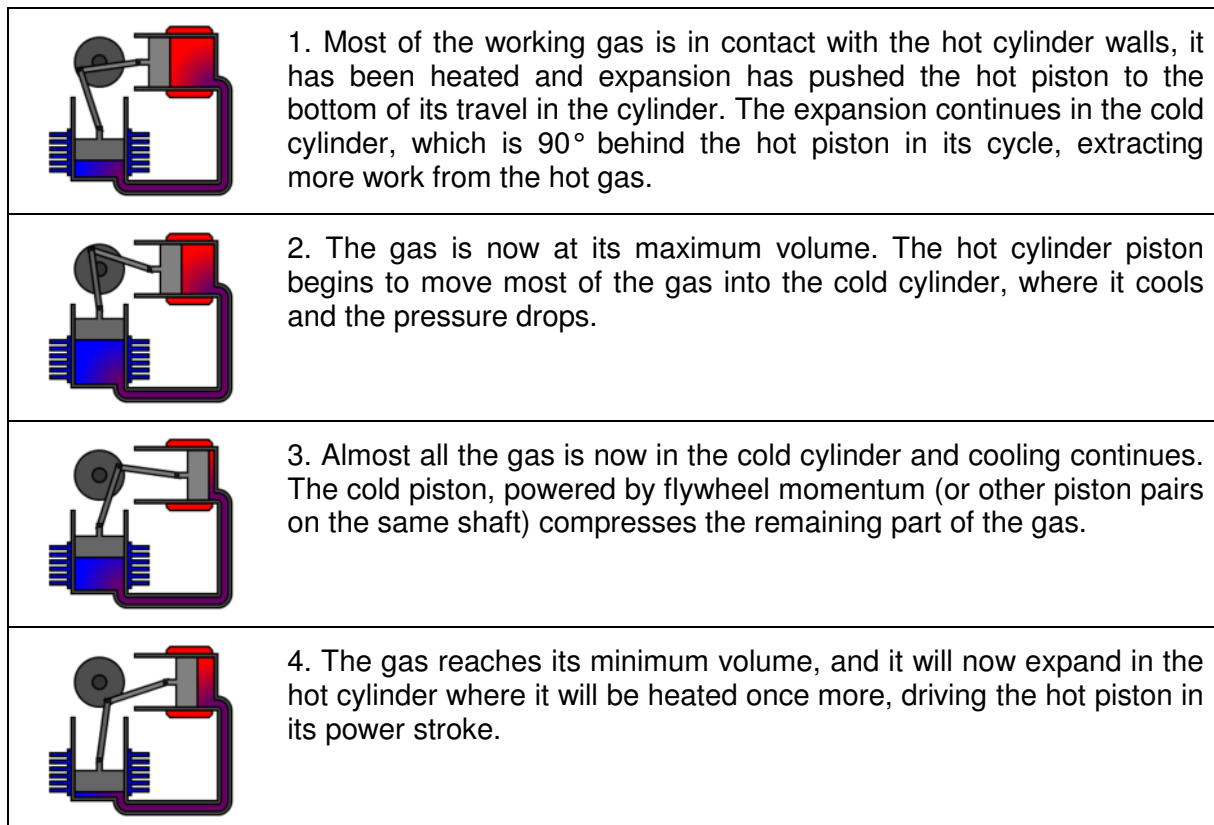

Figure 36: Basic principle of an alpha Stirling engine (Source: Wheeler R. (Zephyris) at Wikipedia 2007)

Generally, Stirling engines have a much lower efficiency than combustion engines and are thus only implemented in niche applications. The use for waste heat from biogas plants is

very limited due to the low waste heat temperatures as the engine operates better at high temperatures (above 900 °C).

Currently, Stirling engines are only commercially available with small capacities of about 40 kW<sub>el</sub>. In addition, the investment costs are still very high. Further challenges include corrosion and fouling at the heat exchanger since the exhaust gas contains sulphur dioxide (SO<sub>2</sub>).

### 3.4.5 Exhaust gas turbine

Another opportunity to increase the total electrical output of a biogas plant is to include an exhaust gas turbine in the exhaust gas stream after the gas engine. The challenge is to avoid corrosion of the turbine, since the exhaust gas has corrosive characteristics. So far, only few manufacturers offer systems with exhaust gas turbines.

Figure 9 shows a dual fuel engine with an integrated exhaust gas turbine. A high-performance gas turbine is integrated in the exhaust gas system of the SCHNELL dual fuel CHP unit. Existing thermal energy is converted into electrical energy using this turbine and the coupled, fast-spinning turbo generator. Through the use of an inverter, 30 kW additional power is gained. According to SCHNELL, the result is 20% increased energy efficiency in comparison with conventional CHP units with Gas-Otto engines.

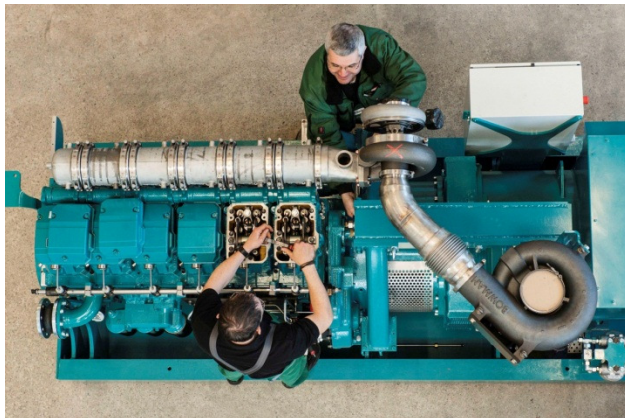

**Figure 37: Dual fuel engine (Gas-Pilot Injection engine) of 235 kW<sub>el</sub> capacity with an integrated exhaust gas turbine of 30 kW<sub>el</sub> capacity (Source: Schnell Motoren AG)**



**Figure 38: Exhaust gas turbine of 30 kW<sub>el</sub> capacity (Source: Schnell Motoren AG)**

## 4 Innovative concepts for efficient biogas conversion

As already shown in previous chapters, many different options exist for the use of biogas. The most common use today, is the combustion of biogas in CHP units for electricity and heat production. This is usually made on the site of the installed biogas plant.

However, in a changing energy supply system moving from fossil fuels towards a larger integration of renewable energy, new concepts for the use of biogas for different applications are being investigated, introduced and applied. Although these concepts are not directly within the scope of the handbook, which focuses on the use of waste heat from biogas plants, they are shortly described to show the full range of biogas uses. Depending on the future energy systems, a new and even more important role may be given to biogas systems. Thereby the role of the use of biogas in conventional CHP units for maximum electricity output may decrease, whereas new biogas use concepts may gain more importance.

### 4.1 Biogas pipelines and satellite CHP units

One approach that efficiently uses the energy content of biogas is to transport the biogas via gas pipelines (biogas micro-grids) to so called **satellite CHP units**, which are located close to a heat consumer (Figure 40, Figure 39). An increasing number of projects set-up such systems with one or several CHP units. These projects are usually implemented for biogas plants which do not have a larger heat consumer on the plant site. In order to fully use the heat, biogas is transported via a dedicated biogas pipeline to the consumers. It is a good alternative to the set-up of small district heating systems in which the pipelines transport the hot water to the consumers.

In Table 10, a general comparison is made for biogas and heat pipelines. The selection of the system is influenced by many local factors and includes technical, economic and legal issues. Generally, biogas pipelines and biogas micro-grids usually perform better than small district heating grids, proportionally to the dimension of the grids. A heat distribution system is needed also for a biogas micro-grid, but energy losses are much smaller since it is in the vicinity of the satellite CHP.

A prerequisite for transporting biogas in pipelines to satellite CHP units is good drying of the gas. If the gas is too wet, water condensates in the pipelines and leads to corrosion and blocking. Furthermore, the gas needs to be desulfurized to avoid corrosion of the pipelines.



Figure 39: Start of biogas pipes to a satellite CHP unit to the town of Trebon, Czech Republic (Source: D. Rutz)

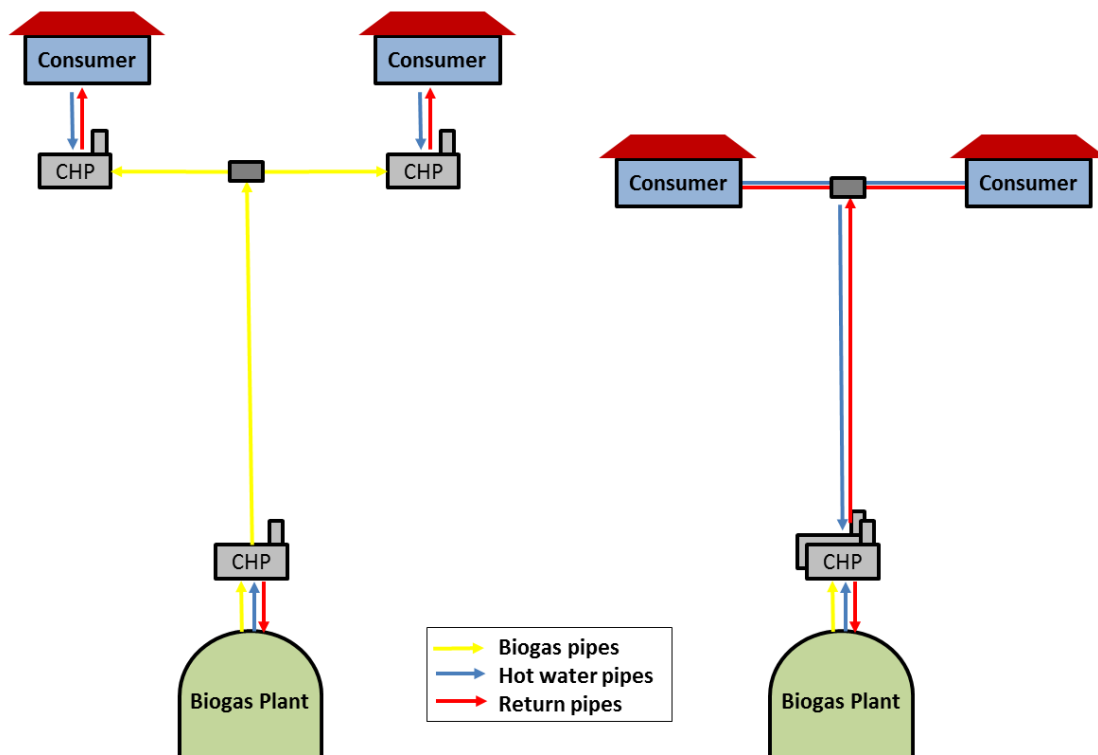

Figure 40: Biogas pipeline to satellite CHPs (left) and micro-district heating system (right)

**Table 10: Comparison of different characteristics of biogas and heat pipelines**

Characteristics	Biogas pipeline	Heat pipeline
<b>Location of CHP units</b>	Usually one CHP unit at the biogas plant (for digester heating) and several as satellite CHPs at the end of the biogas pipeline	One or several CHP units centralized at the biogas plant
<b>Transported medium</b>	Biogas	Hot water
<b>Compressor/pump</b>	Gas compressor	Water circulation pump
<b>Pipeline number</b>	Only one pipeline needed	Supply and return pipelines needed for a closed water circuit
<b>Pipeline</b>	Gas pipelines; resistant to corrosion; anticorrosive coated steel or synthetic pipes	Insulated district heating pipelines; usually consisting of synthetic material
<b>Losses</b>	Low gas losses	Heat losses depend on insulation, but losses in energy content are generally higher than gas losses.
<b>Preparation measures</b>	Gas drying, desulphurisation (<10ppm), pressurising	Water heating
<b>Legal framework conditions</b>	Legal situation often not yet clear and classification of biogas pipelines not defined; Higher safety requirements apply	Usually approved system
<b>Costs</b>	Costs for gas compressors are much higher than for water circuit pumps	Installation costs for heating pipeline is usually higher
<b>Maturity of implementation</b>	Only few examples in some countries exist	Small district heating systems are widely applied
<b>General suitability</b>	Better for longer distances	Better for smaller distances

#### 4.2 Biogas upgrading and grid injection of biomethane

Another option for efficiently using biogas is the upgrading of biogas to biomethane quality and adjacent injection of the biomethane into the natural gas grid. In the upgrading process, biogas is in a first step cleaned from impurities such as hydrogen sulphide, water, nitrogen ammonia, siloxanes, particles and oxygen. The removal of these substances and the needed level of purity depends on the second step in which the CO<sub>2</sub> is removed, whereas the methane content is increased from 45-70% CH<sub>4</sub> to >95% CH<sub>4</sub>. Thereby, the energy density increases. Core of the whole process is the upgrading technology which can be classified into four categories.

- **Adsorption technologies:** pressure swing adsorption (PSA)
- **Absorption technologies:** water scrubbing, organic physical scrubbing, chemical scrubbing
- **Permeation technologies:** high pressure membrane separation, low pressure membrane separation

- Cryogenic upgrading technologies

The most prevalent method is water scrubbing where high pressure gas flows into a column where the carbon dioxide and other trace elements are scrubbed by cascading water running counter-flow to the gas.

After the upgrading process, biomethane is conditioned (fine-tuning of the gas composition and the heating value), odorised and pressurised in order to be injected in the natural gas grid.

In the last years, the number of biogas upgrading plants increased steadily. Currently in Germany about 100 upgrading plants are in operation. Also in other countries like Sweden, Switzerland and Austria, upgrading plants are installed. The main benefit is that once the biomethane has entered the natural gas grid, it can be easily stored and consumed at any place with natural gas grid access. Thereby, the full energy content can be utilised, since the biogas can be consumed e.g. at locations of heat consumers. The main disadvantages of upgrading plants can be summarised as follows:

- Higher investment costs apply for the whole process.
- It is currently suitable only for larger plants due to high costs.
- Energy is needed for the upgrading process.
- Framework conditions are not suitable in many countries.

The concept of using waste materials for biogas production with adjacent upgrading to biomethane, also called Waste-to-Biomethane (WtB), is promoted by the UrbanBiogas project (Urban waste for biomethane grid injection and transport in urban areas) in 5 European cities (Rutz et al. 2011; Rutz et al 2012). In many European regions waste management is still a major problem and only few plants use organic waste for biomethane production.



**Figure 41: Pressure Swing Absorption (PSA) technology at Aiterhofen, Germany (Source: Rutz)**



**Figure 42: Water scrubber upgrading plant of Swedish Biogas International at Lidköping, Sweden (Source: Rutz)**

### 4.3 Biomethane transport in containers

At locations with no natural gas grid or no access to the natural gas grid, biomethane can be also stored in containers and then transported to the location of consumption. Therefore, the biomethane is pressurised and pumped as so-called Bio-CNG (Compressed Natural Gas) or CBG (Compressed Biomethane Gas) into the containers (Figure 43). This approach is frequently implemented in Sweden, which has only a very small natural gas grid. There, containers of Bio-CNG are brought by trucks to filling stations since most of the biomethane in Sweden is used for transport.

Biomethane can be also liquefied by cooling down to about  $-162^{\circ}\text{C}$ . This can be done with liquid nitrogen. The liquefied biomethane, also called Bio-LNG (Liquefied Natural Gas) or LBG (Liquid Biomethane Gas), is then stored in refrigerated containers which can be transported to the consumers. The main advantage is the higher energy density, which is about 5 times higher than of Bio-CNG, so that long distance transport of the containers becomes more efficient. However, a considerable amount of energy is needed for the liquefaction process. This process is currently only implemented in testing facilities (Figure 44) and may be applied only in future niche applications, such as in ship transport and aviation. The main disadvantages include high costs, high energy losses, and safety risks.



Figure 43: Containers for the transport of CBG of the biogas plant in Borås, Sweden (Source: Rutz)



Figure 44: Biogas plant of Swedish Biogas International producing LBG in Lidköping, Sweden (Source: Rutz)



#### 4.4 Biomethane use in transport

Biomethane is increasingly seen as a viable alternative to other fuels in the transport sector. In many countries the infrastructure for the use of CNG in transport is already very good and networks of CNG filling stations exist.

Once biomethane is injected into the natural gas grid, it can be also used for transport with the same infrastructure as for CNG vehicles (Rutz & Janssen 2008). Nevertheless, dedicated CBG filling stations are still rare. Usually mixed CNG/CBG fuels are offered. In some cases, pure CBG is offered, sometimes even directly on the site of the biogas plant. Forerunners in using CBG in Europe are Sweden and Switzerland.

A major challenge in using CBG (as well as CNG) is the storage of the biomethane in the vehicle and the limited maximum driving distance with one fuelled tank. Often dual fuel systems for methane and for petrol/ethanol or diesel are used. Many light and heavy duty vehicles are converted vehicles, which have been retro-fitted with a compressed gas tank, in the luggage compartment, and a gas supply system, in addition to the fossil fuel system (Al Seadi et al. 2008).

There is also an increasing number of dedicated biomethane vehicles, which are optimised for better efficiency and a better placement of the gas tanks, without losing luggage space. The biogas is stored at 200 to 250 bars in pressure vessels made of steel or aluminium composite materials (ibid.).



Figure 45: Biomethane filling station of Svensk Biogas in Linköping, Sweden (Source: Rutz)



Figure 46: Tank for CBG of a truck, Sweden (Source: Rutz)

#### 4.5 Biogas as load management and for grid stability

A key-challenge of future energy systems and especially of future electricity systems is the integration of many different smaller and decentralized energy sources in the overall energy system. With increasing amounts of wind and solar power fed into the electricity grids, new and intelligent management systems have to be found in order to keep the electricity system stable. An important role in stabilising the future electricity grid will be energy storage systems as well as systems that can react on changing loads in the system in a short time. Intelligent electricity grids with automatically interacting and communicating electricity supply and demand systems are also called **smart grids**.

Natural gas, biogas and biomethane are energy carriers that can be easily stored at different sizes from small gas storages, which are part of each biogas plant, to large-scale storages such as the natural gas grid itself. Furthermore, electricity from gas generators (turbines, engines) can be switched on and off within a very short timeframe. Thus, these systems are very suitable to stabilize the grid and to balance loads.

Electricity from biogas and biomethane CHP units can contribute to stabilize the grid. In terms of practical application this means that a biogas plant operator would adjust the operation of the CHP unit according to the demand for electricity in the grid. This could simply happen by switching on and off the CHP unit. Therefore, the biogas plant operator has to receive a signal from the grid operator or electricity trader. With these signals, the operation of the CHP could be adjusted automatically.

However, the objective of biogas plant operators is usually to maximize the electricity output, especially when benefitting of a fixed feed-in tariff for each kWh fed into the electricity grid. If the biogas plant operator would be involved in stabilizing the electricity grid, the CHP units could be switched-off regularly. For this added service and for the lost revenues from the feed-in tariff, the biogas plant operator would have to be compensated. Furthermore, the plant operator has to be compensated also for the investment of additional biogas storage capacities.

Apart from additional storage capacity for biogas, the biogas plant operator may even adjust the anaerobic digestion process by adjusting the feedstock input to the digester. Since the reaction of the AD process is inert and needs time to react, information on the needed electricity production has to be forecasted and transmitted to the plant operator.

Several research and demonstration projects have implemented such intelligent systems already and proofed its viability (E-Energy, AlpEnergy).

#### 4.6 Biomethane and Power-to-Gas

In the **Power-to-Gas** concept (Figure 47), surplus electricity is converted into **synthetic methane**. With increasing number of wind and solar (photovoltaic) power installations, surplus electricity is produced more frequently. This happens at times when more renewable electricity is generated than can be used or transported across the power grid. One option to solve the problem in order to keep the power grid stable is to switch off these wind and solar power installations. Another option is to use this surplus electricity in order to produce synthetic methane.

Surplus electricity splits water by **electrolysis** into oxygen and hydrogen. The hydrogen and CO<sub>2</sub> input (e.g. from a biogas upgrading plant) is converted in a Sabatier process (Equation 15) into methane. This methane is injected in the natural gas grid and acts as natural gas substitute.

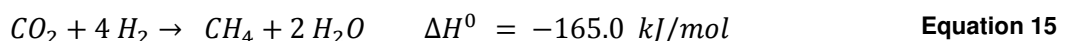

The process can be combined either with a biogas upgrading plant which supplies the CO<sub>2</sub> into the system, or with a common biogas plant which supplies conventional biogas, which also contains high amounts of CO<sub>2</sub>, into the system.

The storage capacity of the natural gas grid in which the synthetic methane is injected is very large. The Power-to-Gas system is an alternative to hydropower storage systems in areas where no hydropower infrastructure can be set-up. It is also an alternative to other storage systems, such as batteries, flying wheels, compressed air, etc. A prerequisite for the system is the availability of a water source as well as of a CO<sub>2</sub> source. The produced oxygen is a co-product that may be also commercialised.

According to the Worldwatch Institute (2012) one major drawback to this approach is the significant energy loss involved. The conversion of electricity into methane occurs with an efficiency of only up to 60%. If the methane is later used in a natural gas power plant to produce electricity, the efficiency falls to 36%. Pumped hydro storage, on the other hand, stores energy at an efficiency rate of 70 to 80%. From the environmental viewpoint, it is however certainly better to use this technology than to “loose” electricity if the wind and solar power generators have to be switched-off.

In Germany, which has large capacities of wind energy in the North and a high electricity demand in the South, Gas-to-Power systems could be one measure to stabilize the power grid. Several research and demonstration facilities are currently being set-up, as shown in the following list (Dena 2012).

- Enertrag-Hybridkraftwerk, Prenzlau
- E.ON-Pilotanlage, Falkenhagen
- SolarFuel-Alpha-Anlage, Stuttgart
- 250-kW-Power-to-Gas-Pilotanlage, Stuttgart
- Audi-e-gas-Anlage, Werlte
- Demonstrations- und Innovationsprojekt RH2, Werder/Kessin/Altentreptow

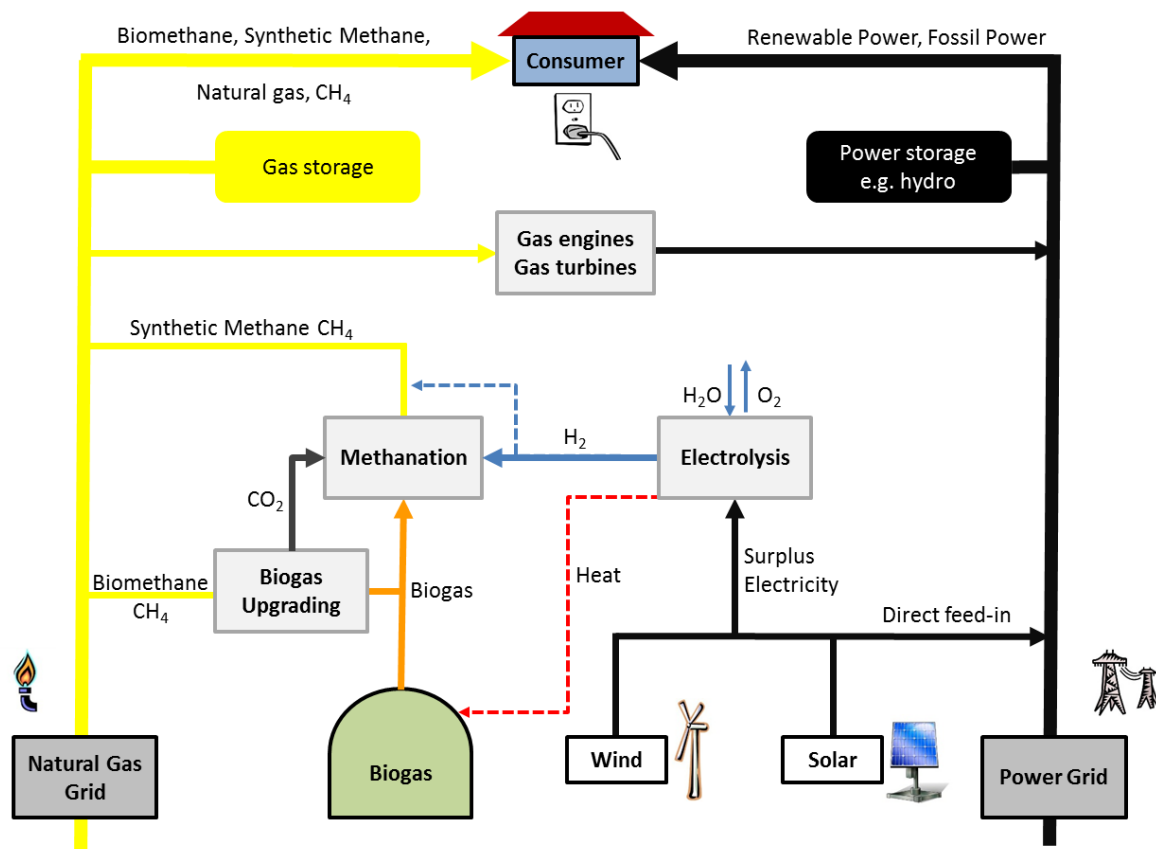

Figure 47: Power-to-Gas concept

## 5 Guideline on heat use options

As it is shown in this handbook, many different options exist for the efficient use of biogas. The objective of all of them is to maximise the energy use from biogas conversion.

For a biogas plant operator, the main objective is to maximise the revenues from biogas production while fulfilling legal requirements. Therefore, this chapter gives advice on how to select the best heat use options for the plant operator, according to different framework conditions.

The most efficient and profitable use of biogas is its **conversion into electricity and heat with an efficient and modern CHP unit, using the heat directly at the location of the biogas plant**. Thereby the heat can be used for different purposes. However, the situation where the electricity output as well as the heat supply and demand can simultaneously be maximised rarely occurs in real situations.

A very good general alternative to the simultaneous maximisation of the electricity and heat use is the injection of upgraded biogas into the natural gas grid. Thereby the biomethane can be used in satellite CHP units at locations with high simultaneous electricity and heat demand. However, the investment costs of upgrading plants are very high and usually upgrading projects are implemented in larger projects.

In the initial planning phase of projects on waste heat recovery of biogas plants, the following four **key questions** need to be considered, before starting with an in-depth investigations of the project:

- Can the heat from the CHP unit be **used at the own facility** (e.g. digester heating, heating of own houses and stables, cooling and drying of agricultural products, digestate and sewage sludge drying, hygenisation, etc.)? How much heat can be used for own purposes?
- Is there an **external potential heat consumer in the vicinity of the plant**? How reliable is the heat demand? How far is the heat consumer away from the biogas plant? Is the heat demand continuous or seasonal? Which type and duration of contracts can be made with the heat consumer?
- If no heat consumer can be found, **is it possible to “create” a new heat consumer** close to the plant (e.g. drying facility, glasshouse, aquaculture)?
- If no heat consumer can be found, **would a biogas upgrading plant be feasible**? Is the plant large enough? How far is the natural gas grid away? Is there legal support for biomethane production?

In addition to these questions, the following checklist includes important aspects which should be considered for a more detailed planning process:

*What is the main **objective** of the biogas plant?*

- Current situation of the plant (existing or planned plant)
- Maximisation of electricity and heat production (and revenues from feed-in tariff)
- Maximisation of heat output
- Contribution to load management with additional gas storage and CHP capacities

*What are the **legal** opportunities and limitations?*

- Applicable laws to renewable electricity production from biogas

- Specific legal aspects regarding heat use, efficiency, size of the plant, etc. (e.g. 60% heat use mandate in Germany)
- Specific legal aspects regarding additional gas storage capacity
- Specific legal aspects on the contribution to the power grid stability
- Specific legal aspects on land classification and protection (e.g. protected areas)
- Specific legal aspects on safety
- Permitting procedures

What are the **site-specific** limitations?

- Available space for additional installations
- Ownership of affected stakeholders (e.g. pipelines passing through different properties)
- Land classification and protection (e.g. protected areas)

Which **technological aspects** have to be considered?

- Additional biogas storage capacity
- Additional CHP capacity for electricity peaks
- Additional gas burners for heat peaks
- Lifetime of equipment
- Maintenance requirements
- Maturity and reliability of the technology
- Technical monitoring

Which **financial aspects** are related to the project?

- Price for electricity
- Price for heating and cooling
- Price for other services such as drying
- Price of aquaculture products
- Investment costs for additional equipment and installations
- Costs of capital (interest rate)
- Ratio of equity and debt
- Costs for additional equipment
- Costs for replacement of equipment
- Costs for operation and maintenance
- Costs for additional labour
- Available public support schemes

What are the **operator's capacities**?

- Operator's expertise and qualification
- Qualified personnel
- Additional labour time

Which **contractual relationships with (business) partners** are relevant?

- Electricity supply contracts
- Heat supply contracts
- Duration of the contracts
- Guaranteed or non-guaranteed supply
- Reliability of manufacturers
- Existing experiences with business partners
- Acceptance of neighbours
- Private or public partners
- Investors

## **6 Conclusions**

Finally, it can be concluded that the most common heat concepts for **agricultural biogas plants** today include the direct use of heat for own purposes (houses, stables) and for solid biomass drying in agricultural plants. Thereby, the heat supply often surpasses the heat availability (in summer) and still a large fraction of heat is wasted. Some plants use the heat for drying of cereals and for small district heating supply. The use of heat for glasshouse acclimatisation, for cooling and for aquaculture is still a niche application.

The most common heat concepts for heat use of **waste biogas plants** is for own purposes such as for hygienisation and sanitation. Some plants also supply heat to district heating systems. Furthermore, some plants are using the heat to dry the digestate. The same applies for wastewater treatment plants using sewage sludge as feedstock.

In Sweden, as a special case, upgrading of biogas to biomethane and adjacent distribution to biomethane filling stations is most common.

In Germany, the establishment of upgrading plants for injecting biomethane into the natural gas grid is increasing. Out of about 7,500 installed biogas plants, approximately 100 upgrading plants are installed today. The governmental plan is to increase this number significantly.

Limited resources availability, land use competition, as well as increased competition on waste materials are increasing the pressure on biogas plants. It will therefore become more and more important to maximize the usable energy output of biogas. This means to set-up sound and efficient heat concepts for common biogas plants with CHP units. Without a sound heat concept, future biogas plants risk losing their economic feasibility and environmental performance.

The objective of a maximised energy output also applies to biogas upgrading plants.

The use of biomethane in transport plays a special role: currently, the transport sector heavily relies on carbon based transport fuels. The use on non-carbon based fuels (hydrogen, electricity) only plays a minor role in the current transport system. As biomethane is also a carbon based fuel, it could significantly contribute to the future energy mix in the transport sector. This is important as the alternatives to carbon based transport fuels are very limited. Thereby, the general lower energy efficiency of vehicle combustion engines could be accepted.

## Glossary and Abbreviations

*The Glossary and Abbreviations list describes and defines various specific or common expressions, terms and words, which are used in this handbook. A major aim of this list is to facilitate translations of the handbook into national languages. Several expressions are adapted from Wikipedia.*

**Absorption:** process in which atoms, molecules, or ions enter some bulk phase (gas, liquid, or solid material). This is a different process from adsorption, since molecules undergoing absorption are taken up by the volume, not by the surface (as in the case for adsorption).

**AD:** see Anaerobic digestion

**Adsorption:** the adhesion of atoms, ions, or molecules from a gas, liquid, or dissolved solid to a solid surface

**Ammonia:** A gaseous compound of hydrogen and nitrogen,  $\text{NH}_3$ , with a pungent smell and taste.

**Anaerobic digestion:** Also called digestion or fermentation: A microbiological process of decomposition of organic matter, in the complete absence of oxygen, carried out by the concerted action of a wide range of micro-organisms. Anaerobic digestion (AD) has two main end products: biogas (a gas consisting of a mixture of methane, carbon dioxide and other gases and trace elements) and digestate (the digested substrate). The AD process is common to many natural environments and it is applied today to produce biogas in airproof reactor tanks, commonly named digesters.

**Aquaculture:** Aquaculture, also known as aquafarming, is the farming of aquatic organisms such as fish, crustaceans, molluscs and aquatic plants. Aquaculture involves cultivating freshwater and saltwater populations under controlled conditions, and can be contrasted with commercial fishing, which is the harvesting of wild fish. Aquaculture can be made in natural or artificial water bodies or in closed artificial systems.

**Aquaponic:** artificial word consisting of the words aquaculture (fish) and hydroponic (vegetables).

**Barium hydroxide:** chemical compound with the formula  $\text{Ba}(\text{OH})_2$ . Also known as baryta, it is one of the principal compounds of barium. The white granular monohydrate is the usual commercial form.

**Barrel of oil equivalent (boe):** The amount of energy contained in a barrel of crude oil, i.e. approx. 6.1 GJ, equivalent to 1,700 kWh. A "petroleum barrel" is a liquid measure equal to 42 U.S. gallons (35 Imperial gallons or 159 liters); about 7.2 barrels are equivalent to one tonne of oil (metric).

**Bio-CNG:** see Compressed Biomethane Gas

**BiogasHeat:** Project (Development of sustainable heat markets for biogas plants in Europe) funded by the Intelligent Energy for Europe Programme of the European Commission in which this handbook was elaborated.

**Biogas:** Gas resulting from anaerobic digestion consisting of mainly methane and carbon dioxide, but also of hydrogen sulphide, water and smaller fractions of other compounds

**Bio-LNG:** see Liquefied Biomethane Gas

**Biomethane:** Upgraded biogas to natural gas quality with  $\text{CH}_4$  content >95%

**Capacity:** The maximum power that a machine or system can produce or carry safely (the maximum instantaneous output of a resource under specific conditions). The capacity of generating equipment is generally expressed in kilowatts or megawatts.

**Carbon dioxide:** CO<sub>2</sub> is a naturally occurring chemical compound composed of two oxygen atoms covalently bonded to a single carbon atom. It is a gas at standard temperature and pressure and exists in Earth's atmosphere in this state, as a trace gas at a concentration of 0.039% by volume.

**CBG:** see Compressed Biomethane Gas

**CH<sub>4</sub>:** see Methane

**CHP:** Combined heat and power: (Syn. Co-generation): The sequential production of electricity and useful thermal energy from a common fuel source. Reject heat from industrial processes can be used to power an electric generator (bottoming cycle). Conversely, surplus heat from an electric generating plant can be used for industrial processes, or space and water heating purposes (topping cycle).

**Clausius-Rankine-Cycle (CRC):** Thermodynamic closed cycle in which usually water is heated, evaporated and passed through a turbine that moves the generator for electricity production.

**CNG:** Compressed Natural Gas

**CO<sub>2</sub>:** see Carbon dioxide

**Coefficient of performance (COP):** The coefficient of performance or COP (sometimes CP), of a heat pump is the ratio of the change in heat at the "output" (the heat reservoir of interest) to the supplied work. The COP was created to compare heat pumps according to their energy efficiency.

**Co-generation:** see combined heat and power generation (CHP)

**Compressed biomethane gas:** CBG is made by compressing biomethane. As it has the same properties of CNG, see the description of "Compressed natural gas".

**Compressed natural gas:** CNG is made by compressing natural gas, to less than 1% of the volume it occupies at standard atmospheric pressure. It is stored and distributed in containers and tanks at a pressure of 200–248 bar (2,900–3,600 psi).

**Condensing boiler:** Condensing boilers are water heaters with high efficiencies (typically greater than 90%) which are achieved by using the waste heat in the flue gases to pre-heat the cold water entering the boiler. They may be fuelled by gas or oil and are called condensing boilers because the water vapour produced during combustion is condensed into water, which leaves the system via a drain.

**Cooling:** Cooling is the transfer of thermal energy via thermal radiation, heat conduction or convection thereby changing the temperature from the targeted system from higher temperature levels to lower temperature levels.

**COP:** see Coefficient of performance

**CRC:** see Clausius-Rankine-Cycle

**DH:** District heating

**DHC:** District heating and cooling

**DHW:** Domestic hot water supply

**Digestate:** The treated/ digested effluent from the AD process. (Syn. AD residues, digested biomass, biogas digested slurry)

**Digester:** (sometimes also called fermenter) closed tank, usually vertical or horizontal cylinder form, or garage (for dry digestion), in which the anaerobic digestion process takes place

**Digestion:** see Anaerobic Digestion



**District cooling:** District cooling is a system for distributing chilled water or water/ice mixtures from a centralized location for residential and commercial cooling such as air conditioning.

**District heating:** District heating is a system for distributing heat (by hot water or steam) generated in a centralized location for residential and commercial heating requirements such as space heating and water heating.

**Dual Fuel Engine:** see Gas-Pilot Injection Engine

**EER:** see Energy efficient ratio

**Electrolysis:** Electrolysis is a method of using a direct electric current (DC) to drive an otherwise non-spontaneous chemical reaction. For instance, electrolysis can split water into its elements hydrogen and oxygen.

**Energy efficient ratio (EER):** the ratio of cold output to electricity input for a specified source.

**Energy service company (ESCO, ESCO):** An energy service company is a commercial business providing a broad range of comprehensive energy solutions including designs and implementation of energy savings projects, energy conservation, energy infrastructure outsourcing, power generation and energy supply, and risk management.

**Enthalpy:** Enthalpy is a measure of the total energy of a thermodynamic system. It includes the internal energy, which is the energy required to create a system, and the amount of energy required to make room for it by displacing its environment and establishing its volume and pressure.

**Entropy:** Entropy is a measure of how evenly energy is distributed in a system. In a physical system, entropy provides a measure of the amount of energy that cannot be used to do work.

**ESCO:** see Energy Service Company

**Exergy:** In thermodynamics, the exergy of a system is the maximum useful work possible during a process that brings the system into equilibrium with a heat reservoir. When the surroundings are the reservoir, exergy is the potential of a system to cause a change as it achieves equilibrium with its environment. Exergy is the energy that is available to be used. After the system and surroundings reach equilibrium, the exergy is zero. Determining exergy was also the first goal of thermodynamics.

**Exhaust gas:** Gas that is released after the combustion from a combustion device (burner, engine); It contains mainly CO<sub>2</sub>, but also other compounds.

**Exhaust gas turbines:** gas turbines that use part of the exhaust gas for additional power production.

**Feed-in:** Feed-in of electricity into the general power network; The equivalent of grid injection of biomethane into the natural gas grid

**Feedstock:** Any input material into a process which is converted to another form or product.

**Fossil fuel:** Fossil fuels are formed in millions of years by natural processes such as anaerobic decomposition of dead organisms.

**Fuel cell:** A device that converts the energy of a fuel directly to electricity and heat, without combustion.

**Gas-Otto engine:** Engine that is specifically designed for the use of gases. They operate based on the Otto principle.

**Gas-Pilot Injection Engine:** Gas-Pilot Injection Engines (also called Pilot Injection Engine or Dual Fuel Engine) are based on the diesel engine principle.

**Gas turbine (syn. Combustion turbine):** A turbine that converts the energy of hot compressed gases (produced by burning fuel in compressed air) into mechanical power. The used fuel is normally natural gas or fuel oil.

**Generator:** A device for converting mechanical energy to electrical energy. In absorption chillers, a generator is the device in which the refrigerant and the transport medium are separated by heat input.

**Global warming potential:** GWP is a relative measure of how much heat a greenhouse gas traps in the atmosphere. It compares the amount of heat trapped by a certain mass of the gas in question to the amount of heat trapped by a similar mass of carbon dioxide. A GWP is calculated over a specific time interval, commonly 20, 100 or 500 years. GWP is expressed as a factor of carbon dioxide whose GWP is standardized to 1. For example, the 20 year GWP of methane is 72, which means that if the same mass of methane and carbon dioxide were introduced into the atmosphere, that methane will trap 72 times more heat than the carbon dioxide over the next 20 years.

**Greenhouse gas (GHG):** Gases that trap the heat of the sun in the Earth's atmosphere, producing the greenhouse effect. The two major greenhouse gases are water vapour and carbon dioxide. Other greenhouse gases include methane, ozone, chlorofluorocarbons, and nitrous oxide.

**Grid injection:** Injection of biomethane into the natural gas grid; The equivalent in the electricity sector is feed-in

**GWP:** see Global warming potential

**H<sub>2</sub>:** see Hydrogen

**H<sub>2</sub>O:** see water

**H<sub>2</sub>S:** see Hydrogen sulphide

**Heat:** Heat is energy transferred from one system to another by thermal interaction. In contrast to work, heat is always accompanied by a transfer of entropy. Heat flow from a high to a low temperature body occurs spontaneously. This flow of energy can be harnessed and partially converted into useful work by means of a heat engine. The second law of thermodynamics prohibits heat flow from a low to a high temperature body, but with the aid of a heat pump external work can be used to transport energy from low to the high temperature. In ordinary language, heat has a diversity of meanings, including temperature. In physics, "heat" is by definition a transfer of energy and is always associated with a process of some kind. "Heat" is used interchangeably with "heat flow" and "heat transfer". Heat transfer can occur in a variety of ways: by conduction, radiation, convection, net mass transfer, friction or viscosity, and by chemical dissipation.

**Heat exchanger:** Device built for efficient heat transfer from one fluid to another, whether the fluids are separated by a solid wall so that they never mix, or the fluids are directly contacted.

**Heating value:** the amount of heat released during the combustion of a specified amount of a fuel (biogas, biomethane).

**Heat transfer efficiency:** ratio of the useful heat output and the actual heat produced in the combustion device.

**h-x diagram:** Mollier-h-x-Diagramm enables to define changing characteristics of humid air by heating, cooling, moistening and drying

**Hydrogen:** H<sub>2</sub> is the lightest element and its monatomic form (H<sub>1</sub>) is the most abundant chemical substance, constituting roughly 75% of the Universe's baryonic mass. At standard temperature and pressure, hydrogen is a colourless, odourless, tasteless, non-toxic, non-metallic, highly combustible diatomic gas with the molecular formula H<sub>2</sub>. Naturally, atomic hydrogen is occurring rarely on Earth.

**Hydrogen sulphide:** H<sub>2</sub>S is a colourless, very poisonous, flammable gas with the characteristic foul odour of rotten eggs. It often results from the bacterial breakdown of organic matter in the absence of oxygen (anaerobic digestion).

**Hygienisation:** Hygienisation is a thermal and/or pressure pre-treatment method of feedstock (wastes) to reduce the pathogenic micro-organisms in the feedstock.

**Humidity:** Humidity is a term for the amount of water vapour in the air

**Installed capacity:** The installed capacity is the total electrical or thermal capacity of energy generation devices.

**Joule (J):** Metric unit of energy, equivalent to the work done by a force of one Newton applied over a distance of one meter. 1 joule (J) = 0.239 calories; 1 calorie (cal) = 4.187 J.

**ibid.:** (ibidem) is the term used to provide a citation or reference for a source that was cited just before.

**Kalina process:** The Kalina process or cycle is a thermodynamic process for converting thermal energy into usable mechanical power. It uses a solution of 2 fluids with different boiling points for its working fluid.

**Kilowatt (kW):** A measure of electrical power or heat capacity equal to 1,000 watts.

**Kilowatt-hour (kWh):** The most commonly-used unit of energy. It means one kilowatt of electricity or heat supplied for one hour.

**kW<sub>el</sub>:** electrical power (capacity)

**kWh:** see Kilowatt-hour

**kW<sub>th</sub>:** thermal (heat) capacity

**Latent heat:** Latent heat is the heat released or absorbed by a body or a thermodynamic system during a process that occurs without a change in temperature. A typical example is a change of state of matter, meaning a phase transition such as the melting of ice or the boiling of water. In contrast to latent heat, sensible energy or heat causes processes that do result in a change of the temperature of the system.

**LBG:** Liquefied Biomethane Gas

**Liquefied biomethane gas:** biomethane that is liquid since it is cooled down below the boiling point of about -160°C

**Liquefied natural gas:** natural gas that is cooled down below the boiling point of about -160°C

**Liquid petroleum gas:** LPG is a fossil based propane-butane mixture and also called GPL, or LP Gas.

**Load curve:** A load curve is a graph that shows the actual heat or electricity consumption over the course of time, usually one year (8,760 hours).

**Load duration curve:** A load duration curve is similar to a load curve but the load data are ordered in descending order of magnitude, rather than chronologically.

**Low calorific value burner:** A LCV burner combusts low calorific gas (heating value of below 8.5 MJ/Nm<sup>3</sup>).

**LNG:** see Liquefied Natural Gas

**LPG:** see Liquid Petroleum Gas

**Natural gas:** Natural gas is a fossil hydrocarbon gas mixture consisting primarily of methane, with other hydrocarbons, carbon dioxide, nitrogen and hydrogen sulphide.

**NH<sub>3</sub>:** see Ammonia

**Nm<sup>3</sup>:** In countries using the SI metric system of unit, the term "normal cubic metre" (Nm<sup>3</sup>) is very often used to denote gas volumes at some normalized or standard condition. There is no universally accepted set of normalized or standard conditions. In Germany, the Nm<sup>3</sup> is the volume of a gas at the following normal conditions: 1.01325 bar, humidity of 0% (dry gas), 0°C (DIN) or 15°C (ISO).

**m<sup>3</sup>:** A cubic meter is the volume of 1x1x1 m. One cubic metre is about 1 t of water.

**Mesophilic process:** AD process with temperature of 25°C – 45°C

**Methane:** CH<sub>4</sub> is a flammable, explosive, colourless, odourless, tasteless gas that is slightly soluble in water and soluble in alcohol and ether; boils at – 161.6°C and freezes at – 182.5°C. It is formed in marshes and swamps from decaying organic matter, and is a major explosion hazard underground. Methane is a major constituent (up to 97%) of natural gas, and is used as a source of petrochemicals and as a fuel. It is a combustible gas at normal conditions and a relatively potent greenhouse gas.

**Micro-gas turbine:** Small combustion turbine with an output of 25 to 500 kW. Microturbines are composed of a compressor, combustor, turbine, alternator, recuperator and generator. Relative to other technologies for smallscale power generation, micro-turbines offer a number of advantages, including: a small number of moving parts, compact size, light weight, greater efficiency, lower emissions, lower electricity costs, potential for low cost mass production, and opportunities to utilise waste fuels.

**Mini-grid:** An integrated local generation, transmission and distribution system (for electricity or heat) serving numerous customers.

**Moisture:** Ratio of the mass of water content of a material (biomass) and the mass of the dry material itself.

**mol:** The mole is a SI unit used in chemistry to express amounts of a chemical substance, defined as an amount of a substance that contains as many elementary entities (e.g., atoms, molecules, ions, electrons) as there are atoms in 12 grams of pure carbon. This corresponds to a value of 6.02214179(30)×10<sup>23</sup> elementary entities of the substance.

**O<sub>2</sub>:** see Oxygen

**ODP:** see Ozone depletion potential

**Oil equivalent:** The tonne of oil equivalent (toe) is a unit of energy: the amount of energy released by burning one tonne of crude oil, approx. 42 GJ.

**ORC:** Organic Rankine Cycle

**Organic Rankine Cycle:** The ORC process is named for its use of an organic, high molecular mass fluid with a liquid-vapour phase change, or boiling point, occurring at a lower temperature than the water-steam phase change. The fluid allows Rankine cycle heat recovery from lower temperature sources such as from biogas plants.

**Oxygen:** At standard temperature and pressure, two atoms of the element bind to form di-oxygen, a very pale blue, odourless, tasteless diatomic gas with the formula O<sub>2</sub>. This compound is an important part of the atmosphere, and is necessary to sustain terrestrial life.

**Ozone depletion potential:** The ODP of a chemical compound is the relative amount of degradation to the ozone layer it can cause, with trichlorofluoromethane (R-11 or CFC-11) being fixed at an ODP of 1.0. Chlorodifluoromethane (R-22), for example, has an ODP of 0.055. CFC 11, or R-11 has the maximum potential amongst chlorocarbons because of the presence of three chlorine atoms in the molecule. ODP is often used in conjunction with a compound's global warming potential (GWP) as a measure of how environmentally detrimental it can be. GWP represents the potential of a substance to contribute to global warming.

**PCM:** see Phase change material

- Phase change material:** PCM is a substance with a high heat of fusion which, melting and solidifying at a certain temperature, is capable of storing and releasing large amounts of energy. Heat is absorbed or released when the material changes from solid to liquid and vice versa.
- Poultry:** is a category of domesticated birds kept by humans for the purpose of collecting their eggs, or killing for their meat and/or feathers.
- Pilot Injection Engine:** see Gas-Pilot Injection Engine
- Power:** The amount of work done or energy transferred per unit of time (definition in physics) as well as electricity from the grid (definition in the energy sector).
- Power-to-Gas:** Process for synthetic methane production by electrolyzing water with surplus electricity
- Pressure Swing Adsorption:** Method of upgrading biogas to biomethane quality.
- Process heat:** Heat used in an for different internal or external process (e.g. for digester heating).
- PSA:** see Pressure Swing Adsorption
- Psychrophilic process:** AD process with temperature below 25°C.
- Rankine cycles:** See Clausius Rankine Cycle
- Satellite CHP:** A combined heat and power unit that is not located at the site of the biogas plant, but at another place. It is connected with the biogas plant through a biogas pipeline.
- Sensible energy:** see Sensible heat
- Sensible heat:** Sensible heat is heat exchanged by a thermodynamic system that has as its sole effect a change of temperature.
- Sewage sludge:** The remaining wet solid sludge of a wastewater treatment plant after treatment.
- SI:** The International System of Units (abbreviated SI from French: *Système international d'unités*) is the modern form of the metric system and is generally a system of units of measurement devised around seven base units and the convenience of the number ten.
- Sodium acetate:** Chemical compound with the formula  $\text{CH}_3\text{COONa}$ , also abbreviated  $\text{NaOAc}$ , also sodium ethanoate, is the sodium salt of acetic acid. This colourless salt has a wide range of uses.
- Smart grid:** A smart grid is an electrical grid that uses information technologies and other technologies in order to adjust the demand and supply in a most efficient way. Smart grids are measures to improve energy efficiency and with the increase of renewable energies it will be more important to stabilise the grid.
- Steam:** Steam is the technical term for water vapour, the gaseous phase of water.
- Stirling engine:** A Stirling engine is a heat engine operating by cyclic compression and expansion of air or other gas, the working fluid, at different temperature levels such that there is a net conversion of heat energy to mechanical work.
- Surplus heat:** See waste heat.
- Synthetic Methane:** Methane produced in the Power-to-Gas process.
- Temperature differential ( $\Delta T$ ):** difference of two temperature levels whereas the result is always positive.
- Thermodynamics:** Thermodynamics is the branch of natural science concerned with heat and its relation to other forms of energy and work. It considers mainly changes in temperature, entropy, volume and pressure that describe average properties of material

bodies and radiation, and explains how they are related and by what laws they change with time.

**Thermophilic process:** AD process with temperature of 45°C – 70°C.

**Turbine:** A machine for converting the heat energy in steam or high temperature gas into mechanical energy. In a turbine, a high velocity flow of steam or gas passes through successive rows of radial blades fastened to a central shaft.

**Vapour:** Vapour is a substance in the gas phase at a temperature lower than its critical point. This means that the vapour can be condensed to a liquid or to a solid by increasing its pressure without reducing the temperature. For example, water has a critical temperature of 374°C (647 K), which is the highest temperature at which liquid water can exist. In the atmosphere at ordinary temperatures, therefore, gaseous water (known as water vapour) will condense to liquid if its partial pressure is increased sufficiently. A vapour may co-exist with a liquid (or solid).

**Waste biogas plants:** Biogas plants that use industrial or municipal organic waste as feedstock

**Waste heat:** Heat from any process, such as from a CHP unit, which is released to the atmosphere and not used. It may be also called surplus heat since “heat” as a type of energy cannot disappear (wasted), according to the law of conservation of energy.

**Water:** H<sub>2</sub>O contains one oxygen and two hydrogen atoms and is a liquid at ambient conditions, but it often co-exists on Earth with its solid state, ice, and gaseous state (water vapour or steam). Water covers 70.9% of the Earth's surface, and is vital for all known forms of life.

**Water content:** Ratio of the mass of water content of a material (biomass) and the mass of the moist material itself.

**Water vapour:** Water vapour is the gas phase of water. See Vapour

**Watt (W):** A standard unit of measure (SI System) for the rate at which energy is consumed by equipment or the rate at which energy moves from one location to another. It is also the standard unit of measure for electrical power. The term 'kW' stands for "kilowatt" or 1,000 watts. The term 'MW' stands for "Megawatt" or 1,000,000 watts.

**Year:** A calendar year is an approximation of the Earth's orbital period in a given calendar. A calendar year in the Gregorian calendar (as well as in the Julian calendar) has either 365 (common years) or 366 (leap years) days. The operational hours of biogas related equipment is usually referred to 8,760 hours.

**yr:** see Year

**Zeolite:** Microporous, aluminosilicate minerals commonly used as commercial adsorbents.

**ΔT:** see temperature differential

## General conversion units

Table 11: Prefixes for energy units

Prefix	Abbreviation	Factor	Quantity
Deco	Da	10	Ten
Hecto	H	10 <sup>2</sup>	Hundred
Kilo	K	10 <sup>3</sup>	Thousand
Mega	M	10 <sup>6</sup>	Million
Giga	G	10 <sup>9</sup>	Billion
Tera	T	10 <sup>12</sup>	Trillion
Peta	P	10 <sup>15</sup>	Quadrillion
Exa	E	10 <sup>18</sup>	Quintillion

Table 12: Conversion of energy units (kilo joule, kilo calorie, kilo watt hour, ton of coal equivalent, cubic metre of natural gas, ton of oil equivalent, barrel, British Thermal Unit)

	kJ	kcal	kWh	TCE	m <sup>3</sup> CH <sub>4</sub>	toe	barrel
1 kJ	1	0.2388	0.000278	3.4 · 10 <sup>-8</sup>	0.000032	2.4 · 10 <sup>-8</sup>	1.76 · 10 <sup>-7</sup>
1 kcal	4.1868	1	0.001163	14.3 · 10 <sup>-8</sup>	0.00013	1 · 10 <sup>-7</sup>	7.35 · 10 <sup>-7</sup>
1 kWh	3.600	860	1	0.000123	0.113	0.000086	0.000063
1 TCE	29,308,000	7,000,000	8,140	1	924	0.70	52
1 m <sup>3</sup> CH <sub>4</sub>	31,736	7,580	8.816	0.001082	1	0.000758	0.0056
1 toe	41,868,000	10,000,000	11,630	1.428	1,319	1	7.4
1 barrel	5,694.048	1,360.000	1,582	0.19421	179.42	0.136	1
1 BTU	1.055						

**Table 13: Conversion of power units (kilo calories per second, kilowatt, horse power, Pferdestärke = horse strength)**

	kcal/s	kW	hp	PS
<b>1 kcal/s</b>	1	4,1868	5,614	5,692
<b>1 kW</b>	0,238846	1	1,34102	1,35962
<b>1 hp</b>	0,17811	0,745700	1	1,01387
<b>1 PS</b>	0,1757	0,735499	0,98632	1

**Table 14: Conversion of temperature units**

	Unit	Celsius	Kelvin	Fahrenheit
<b>Celsius</b>	°C	-	$^{\circ}\text{C} = \text{K} - 273.15$	$^{\circ}\text{C} = (^{\circ}\text{F} - 32) \times 1.8$
<b>Kelvin</b>	K	$\text{K} = ^{\circ}\text{C} + 273.15$	-	$\text{K} = (^{\circ}\text{F} + 459.67) \times 1.8$
<b>Fahrenheit</b>	°F	$^{\circ}\text{F} = ^{\circ}\text{C} \times 1.8 + 32$	$^{\circ}\text{F} = \text{K} \times 1.8 - 459.67$	-

**Table 15: Conversion of pressure units (pascal, bar, technical atmosphere, standard atmosphere, torr, pound per square inch)**

	Pa	bar	at	atm	Torr	psi
<b>1 Pa</b>		0.00001	0.000010197	$9.8692 \times 10^{-6}$	0.0075006	0.0001450377
<b>1 bar</b>	100,000		1.0197	0.98692	750.06	14.50377
<b>1 at</b>	98,066.5	0.980665		0.9678411	735.5592	14.22334
<b>1 atm</b>	101,325	1.01325	1.0332		760	14.69595
<b>1 Torr</b>	133.3224	0.001333224	0.001359551	0.001315789		0.01933678
<b>1 psi</b>	6894.8	0.068948	0.0703069	0.068046	51.71493	



## References

- AlpEnergy (2012) <http://www.alpenergy.net>
- Al Seadi, T., Rutz, D., Prassl, H., Köttner, M., Finsterwalder, T., Volk, S., Janssen, R. (2008). Biogas Handbook. Esbjerg, Denmark: University of Southern Denmark.
- Al Seadi T., Drosch b., Fuchs W., Rutz D., Janssen R. (2013, in print) Digestate quality and utilization. – In: Wellinger A., Murphy J., Baxter D. (eds.) The biogas handbook: Science, production and applications. - Woodhead Publishing Series in Energy No. 52
- BDEW (2009) Erdgas in Gärtnereien. - BDEW Bundesverband der Energie- und Wasserwirtschaft e. V.; Berlin, Germany; <http://www.www.hortigate.de/Apps/WebObjects/Hortigate.woa/vb/bericht?nr=39553>
- Berk J. (2008) Haltung von Jungmasthühnchen (Broiler, Masthähnchen). – DLG Merkblatt 347; Frankfurt am Main, Germany; [http://statictypo3.dlg.org/fileadmin/downloads/merkblaetter/dlg-merkblatt\\_347.pdf](http://statictypo3.dlg.org/fileadmin/downloads/merkblaetter/dlg-merkblatt_347.pdf)
- BMU (2012) Biomass Ordinance (BiomasseV) (as amended as of 1 January 2012); Federal Ministry for the Environment, Nature Conservation and Nuclear Safety; Germany; [http://www.bmu.de/english/renewable\\_energy/downloads/doc/5433.php](http://www.bmu.de/english/renewable_energy/downloads/doc/5433.php)
- Dena (2012) [www.powertogas.info](http://www.powertogas.info) Deutsche Energie Agentur – German Energy Agency [20.07.2012]
- DIRECTIVE 2004/8/EC OF THE EUROPEAN PARLIAMENT AND OF THE COUNCIL of 11 February 2004 on the promotion of cogeneration based on a useful heat demand in the internal energy market and amending Directive 92/42/EEC
- DLR (2012) [http://www.dlr.de/tt/desktopdefault.aspx/tabid-2872/4415\\_read-6487/](http://www.dlr.de/tt/desktopdefault.aspx/tabid-2872/4415_read-6487/) [10.07.2012]
- Dzene I., Rochas C., Rutz D., Janssen R., Ramanauskaite R., Kulisic B., Maras Abramovic J., Malek B., Devetta M., Surowiec M., Amann C., Leutgoeb K., Hinge J., Ofiteru A., Adamescu M., Fevrier N., Froning S. (2012) Development of Sustainable Heat Markets for Biogas Plants. - Proceedings of the 20th European Biomass Conference and Exhibition
- E-Energy (2012) <http://www.e-energy.de/>
- Euroheat & Power: District Cooling The sustainable response to Europe's rising cooling demands. – Brochure; [http://www.euroheat.org/Files/Filer/documents/District%20Heating/Cooling\\_Brochure.PDF](http://www.euroheat.org/Files/Filer/documents/District%20Heating/Cooling_Brochure.PDF) [10.07.2012]
- FNR (2010) Leitfaden Biogas: Von der Gewinnung zur Nutzung. - 5., vollständig überarbeitete Auflage, Fachagentur Nachwachsende Rohstoffe (FNR); Gülzow, Germany; [http://www.fnr-server.de/ftp/pdf/literatur/pdf\\_208-leitfaden\\_biogas\\_2010\\_neu.pdf](http://www.fnr-server.de/ftp/pdf/literatur/pdf_208-leitfaden_biogas_2010_neu.pdf) [10.07.2012]
- FNR (2012) Bioenergy in Germany: Facts and Figures. – Fachagentur Nachwachsende Rohstoffe (FNR); Gülzow, Germany; [http://www.fnr-server.de/ftp/pdf/literatur/pdf\\_484-basisdaten\\_engl\\_web\\_neu.pdf](http://www.fnr-server.de/ftp/pdf/literatur/pdf_484-basisdaten_engl_web_neu.pdf) [10.07.2012]
- Fraunhofer (2012) <http://www.fraunhofer.de/en/press/research-news/2012/june/compact-and-flexible-thermal-storage.html> [10.07.2012]
- Gaderer M., Lautenbach M., Fischer T. (2007) Wärmenutzung in kleinen landwirtschaftlichen Biogasanlagen. – Bayerisches Landesamt für Umweltschutz (LfU), Augsburg, Germany; [http://www.lfu.bayern.de/energie/biogas/doc/machbarkeitsstudie\\_abwaermenutzung.pdf](http://www.lfu.bayern.de/energie/biogas/doc/machbarkeitsstudie_abwaermenutzung.pdf) [10.07.2012]

- Grundfos (2012) <http://www.grundfos.com/service-support/encyclopedia-search/dew-point.html> [10.07.2012]
- Hiegl W., Rutz D., Janssen R. (2011) Information Material Biomass Systems. – Training Handbook for Sanitary and Heating Installers; WIP Renewable Energies, Munich, Germany; Academy for In-Service Teacher Training and Staff Development (ALP), Dillingen a.d. Donau, Germany; Report of the IEE Project Install+RES
- Karalus W. (2007) Ernte und Lagerung von Getreide. - Sächsische Landesanstalt für Landwirtschaft; Dresden, Germany; [http://www.landwirtschaft.sachsen.de/landwirtschaft/download/GetreideimOeL\\_ErnteLager\\_2\\_Kennwortschutz.pdf](http://www.landwirtschaft.sachsen.de/landwirtschaft/download/GetreideimOeL_ErnteLager_2_Kennwortschutz.pdf)
- Kirchmeyr F., Anzengruber G. (2008) Leitfaden zur Wärmenutzung bei Biogasanlagen. – ARGE Kompost und Biogas Österreich; Linz, Austria
- Kralemann M. (2007) Einleitung: Wärmenutzung in Biogasanlagen. - In: Schröder D. Wärmenetze an Biogasanlagen Ein Leitfaden. – Fachkongress am 20 November 2007, Hitzacker; Region Aktiv Wendland/Elbtal; [http://www.projekt-bioenergie.com/wcms/ftp/p/projekt-bioenergie.com/uploads/leitfaden\\_biogaswrmenetze\\_11071.pdf](http://www.projekt-bioenergie.com/wcms/ftp/p/projekt-bioenergie.com/uploads/leitfaden_biogaswrmenetze_11071.pdf) [10.07.2012]
- New Buildings Institute (1998) Guideline: Absorption Chillers. - New Buildings Institute; Fair Oaks; Canada; <http://www.stanford.edu/group/narratives/classes/08-09/CEE215/ReferenceLibrary/Chillers/AbsorptionChillerGuideline.pdf> [10.07.2012]
- Paeger J. (2012) <http://www.oekosystem-erde.de/html/energie.html>
- Ramanauskaite R., Rutz D., Bailon L., Dzene I., Vorisek T., De Filippi F., Amann S., Amann C., (2012): Good Practice Examples for Efficient Heat Use from Biogas Plants. - WIP Renewable Energies; Munich, Germany; Report elaborated in the framework of the BiogasHeat project (Contract Number: IEE/11/025)
- Rutz D., Janssen R. (2008) Biofuel Technology Handbook. - 2nd version; BIOFUEL MARKETPLACE Project funded by the European Commission (EIE/05/022); WIP Renewable Energies, Germany; 152p.
- Rutz D., Janssen R., Letsch H. (2006) Installateurs-Handbuch Biomasseheizanlagen. - EU-IEE EARTH Project; 241p. [www.earth-net.info](http://www.earth-net.info)
- Rutz D., Janssen R., Hoffstede U., Beil M., Hahn H., Kulisic b., Jurić Z., Kruhek M., Ribic B., Haider p., Gostomska A., Nogueira M.A., Martins A.S., Martins M., do Céu Albuquerque M., Dzene I., Niklass M., Gubernatorova I., Schinnerl D., Ruszel m., Pawlak P. (2011) Organic Waste for Biogas Production in Urban Areas. - Proceedings of the 19th European Biomass Conference and Exhibition; pp. 2125-2131; ISBN 978-88-89407-55-7; DOI: 10.5071/19thEUBCE2011-VP3.4.27
- Rutz D., Janssen R., Ramanauskaite R., Hoffstede U., Hahn H., Kulisic B., Bosnjak R., Kruhek M., Ribic B., Surowiec T., Surowiec M., Nogueira M.A., Martins A.S., Duarte D., do Céu Albuquerque M., Martins M., Dzene I., Niklass M., Pubule J., Schinnerl D., Kalandyk k., Zapora D. (2012) The use of Bio-Waste for biomethane Production in European Cities. - Proceedings of the 20th European Biomass Conference and Exhibition; pp. 1481 – 1490; ISBN 978-88-89407-54-7; DOI: 10.5071/20thEUBCE2012-3CO.2.2
- Schröder D. (2007) Konzeption eines Wärmenetzes: Von „Wärmeabfall“ zum wirtschaftlichen Nutzungskonzept. – In: Schröder D. Wärmenetze an Biogasanlagen Ein Leitfaden. – Fachkongress am 20 November 2007, Hitzacker; Region Aktiv Wendland/Elbtal; [http://www.projekt-bioenergie.com/wcms/ftp/p/projekt-bioenergie.com/uploads/leitfaden\\_biogaswrmenetze\\_11071.pdf](http://www.projekt-bioenergie.com/wcms/ftp/p/projekt-bioenergie.com/uploads/leitfaden_biogaswrmenetze_11071.pdf) [10.07.2012]
- Schulz W., Heitmann S., Hartmann D., Manske S., Erjawetz S.P., Risse S., Rübiger N., Schlüter M., Jahn K., Ehlers B., Havran T., Schnober M., Leitfaden Verwendung von

---

Wärmeüberschüssen bei landwirtschaftlichen Biogasanlagen. – Bremer Energie Institut; Bremen, Germany

Skagestad B., Mildenstein P. (no date) District Heating and Cooling Connection Handbook. – International Energy Agency (IEA) District Heating and Cooling. [http://dedc.dk/sites/default/files/programme\\_of\\_research\\_development\\_and\\_demonstration\\_on\\_district\\_heating\\_and\\_cooling.pdf](http://dedc.dk/sites/default/files/programme_of_research_development_and_demonstration_on_district_heating_and_cooling.pdf) [10.07.2012]

Wiese G. (2007) Wärmeverluste: Vorsicht mit pauschalen Angaben! – In: Schröder D. Wärmenetze an Biogasanlagen Ein Leitfaden. – Fachkongress am 20 November 2007, Hitzacker; Region Aktiv Wendland/Elbtal; [http://www.projekt-bioenergie.com/wcms/ftp/p/projekt-bioenergie.com/uploads/leitfaden\\_biogaswrmenetze\\_11071.pdf](http://www.projekt-bioenergie.com/wcms/ftp/p/projekt-bioenergie.com/uploads/leitfaden_biogaswrmenetze_11071.pdf) [10.07.2012]

Worldwatch Institute (2012) <http://blogs.worldwatch.org/revolt/is-%E2%80%9Crenewable-methane%E2%80%9D-energy-storage-an-efficient-enough-option/> [17.07.2012]

